

ST8130 Series Road Car Display Systems

Users Guide

Preface

Congratulations

Congratulations on choosing one of models from the Stack ST8130 Series Road Car Display Systems. This series contains two models:

1. The ST8130 System. This system uses a pulse amplifier to obtain speed information from the vehicle's transmission system.
2. The ST8131 System: This system uses a wheel speed sensor to obtain information about the vehicle's speed directly from one of its wheels.

Either system will give you a wealth of information to enable you to obtain the maximum safe performance from your vehicle.

Registration Form

Please complete and return the registration form contained in the package. This will allow us to keep you up to date on the latest developments from Stack.

Purpose of this manual

This manual will help you install and use either model in the Stack ST8130 Series Road Car Display Systems. It explains how to set up and configure the system for your vehicle.

Edition Notice

This edition is for all versions of the ST8130 Series Road Car Display Systems distributed to customers world-wide. The units of measurement used to illustrate the use of the display systems in this edition are for the UK version. Units used in the various versions are shown in the following table.

Parameter Type	UK Version	US Version	EU Version
Speed	MPH, km/h	MPH	km/h
Distance	Miles	Miles	km
Temperature	°C	°F	°C
Wheel Circumference	Millimetres	Inches	Millimetres
Fuel level	Litres	Gallons (US)	Litres
Pressure	PSI	PSI	Bar

Related Products From Stack Limited

If you need information about other Stack motor sport products, these can be obtained from Stack or from your local Stack dealer. Products available from Stack include:

- Intelligent Tachometers
- Action Replay Tachometers
- Performance Analysers
- Speedometers
- Boost Gauges
- Analogue Sensors
- Digital Sensors
- Data Logging Systems
- Display and Logging Systems
- Radio Telemetry Systems
- Display and Analysis Software

Stack is a registered trademark of Stack Limited.

Information in this publication is subject to change without notice and does not represent a commitment on the part of Stack Limited. No responsibility is accepted for error or omission.

Copyright © 1994, 1995, 1996 Stack Limited

United Kingdom Telephone Numbers:

Sales: 01 869 240404

Tech Support: 01 869 240420

Fax: 01 869 245500

Who to Contact at Stack in Case of Difficulty

Stack and its approved distributors provide a comprehensive Technical Help service to assist with your enquiries. Contact your local Stack branch or distributor.

Approved Stack Distributors

- Australia **Hanco Motor Sport**, Factory B2, 2 Healey Road, Dandenong, Vic 3175.
Tel: 018 312-866 Fax: (3) 794-9959
- Belgium **Van Den Bossche, B.V.B.A.**, Boomsesteenweg 62, 2630 Aartselaar.
Tel: 03 877 30 40 Fax: 03 887 24 52 GSM: 003275 42 96 37
- Canada **Orion Racing**, 2270, Industrial(Laval) Montreal, H7S 1P9
Tel: (514) 667 9769 Fax: (514) 667 6320
- France **Danielson Equipment**, 5 Rue de Champ Magny BP2 ZI 58470, Magny Cours.
Tel: 86 21 22 55 Fax 86 21 22 65
- Oreca Co.**, Parc D'Activite de Signes, 83870, Signes.
Tel: 94 32 80 00 Fax 94 32 80 01
- Germany **ISA Racing**, NeustraÙe 11, 5442 Mendig/Obermendig.
Tel: 26 52 30 61 Fax: 26 52 43 77
- Holland **Verlinden Technology**, Rietdekkersdreef 726, 7328 AL A Apeldoorn
Tel: (31) 055-5427050 Fax: (31) 055-5427050
- Italy **Gi Effe di Ghislieri & Csas**, Via San Giuliano 39, 15040 Castelceriolo (AL)
Tel: 0131 585 215 Fax 0131 585 454
- Sparco SRL.**, Via Lombardia 5-7, 10071 Borgaro Torinese.
Tel: 11 461 1911 Fax 11 461 1900

Japan

SARD Co, 50 Kamisotone, Higashimachi Wakabayashi,
Toyotashi, Aichiken 473.
Tel: 0565 53 1166 Fax: 0565 52 5482

New Zealand **Allport Motorsport**, 5B Olive Road, P.O. Box 12-051,
Penrose, Auckland.

Tel: (9) 579-0113 Fax: (9) 579-0114

South Africa **Automotive Technology Specialists (Pty) Limited**,
Private Bag, X26, Auckland Park 2006.

Tel: (011) 726-6314 Fax (011) 726 2160

Spain **Kernel Technica Auxiliares SA**, Muntaner 83-A, 08011
Barcelona.

Tel: (9) 3 544 404 Fax: (9)3 535 812

Motosport International Dream Machine S.L., Av. Dr.
Wakeman 52 Bajo Der., 46013 Valencia.

Tel: (9)6 333 2044 Fax (9)6 334 7376

Switzerland **HORAG, Hotz Racing AG**, Kreuzlingenstrasse 3, 8583
Sulgen.

Tel: (072) 42 80 20/21 Fax (072) 42 80 30

UK **Stack Limited**,

Wedgwood Road, Bicester, Oxfordshire, OX6 7UL.

Tel: 01869 240404. Fax 01869 245500

Technical Support: 01869 240420

Demon Tweaks,

75 Ash Road South, Wrexham Industrial Estate, Wrexham,
Clwyd. LL13 9YE

Tel: 01978 664 466 Fax 01978 664 467

Gould Engineering Services,

19 Porchester Road, Newbury. Berkshire

Tel: 01635 44466 Fax 01635 30056

P.J. Motorsport, 8 Gypsum Way, Draycott-in-the-Clay,
Ashbourne, Derbyshire,

Tel: & Fax 01283 820625

Prodrive Ltd, Acorn Way, Banbury, Oxon, OX16 7XS.

Tel: 01295 273355 Fax 01295 271188

Road & Racing Accessories Limited,

75-77 Moore Park Road, London SW6 2HH.

Tel: 0171.736 2881 Fax 0171 736 6116

V & M Racing, Lower Place Mill, Shaw Road, Newhey,
Rochdale, OL6 3SR.

Tel: 01706 840066 Fax 01706 882437

U.S.A.

Stack Inc.

5835A Live Oak Parkway, Norcross, GA, 30093 USA.

Tel: Sales(770) 447 0067 Fax (770) 447 0305

Tech Support (770) 449 8246

B.R.I.T.S. Inc.,

28921 Arnold Drive, Unit F-6, Sonoma, CA 95476.

Tel: (707) 935 3637 Fax (707) 935 0942

Dave Schultz Racing, 1871 Ortiz, Fort Myers, FL 33905.

Tel: (813) 332-1918 Fax (813) 332 5636

Epic Racing, 3088 NW 28th Ave.

Boca Raton FL

Tel: (407) 479 4766 Fax: (407) 479 3398

Landmark Motorsports,

2411 East Winston Road, Anaheim CA 92806

Tel : (714) 776 9400 Fax: (714) 776 9439

Linder Brothers,

6748 County Road 9, Edison, OH 43320

Tel : (419) 947 3226 Fax : (419) 947 2305

Transatlantic Racing Services Ltd,

5730, Chattahoochee Ind. Park, Cumming, GA 30131.

Tel: (770) 889 0499 Fax (770) 889 0657

Contents

PREFACE	i
Related Products From Stack Limited	iii
Who to Contact at Stack in Case of Difficulty	v
Approved Stack Distributors	v
CONTENTS	ix
Chapter 1. Introducing the Display Systems	1
ST8130 Model	2
ST8131 Model	2
How to Use this Manual	2
Chapter 2. Getting Started	4
The Display Module	5
Wiring Harness	6
Connecting the Components	7
Chapter 3. Operating the Display System	8
Switching the Display System on	8
Changing the display layers	8
Peak Values (Tell Tales)	11
Alarms	13
Lap times	16
Gear shift light	16
Chapter 4. Configuring the Display System	17
Configuration mode	17
Wheel Pulses and Circumferences	23
Calibrating the Fuel Level	26
Chapter 5. Installing the Display System	31
Who can install the Display System?	31
Tools needed to install the Display System	31
Preconfigured Display Systems	31
Custom Configured Display Systems	31
Fitting the Display Module	32
Switches	33
Warning lights	34

Engine Speed (RPM) Measurement	34
Connecting the Display System to the Ignition System	35
Pressure sensor	37
Temperature sensors	38
Wheel speed sensor	39
Pulse Amplifier Interface (ST492)	40
Fuel Tank Sender	43
Lap timing sensor (optional)	44
Trackside Infra-Red Lap Beacon (optional)	45
Air Temperature Sensor (optional)	46
Wiring harness	46
Checks and Alarms	49
Chapter 6. Troubleshooting	50
Appendix A. Template for the Display Module	61
Appendix B. Wiring Harness Diagram	64
Appendix C. Summary of Switch Functions	65
Returned Goods Form	67
INDEX	68

Chapter 1. Introducing the Display Systems

The two models in the Stack ST8130 Series Road Car Display Systems monitor and display a range of values, known as performance parameters, needed for effective car and driver management in most driving situations. The models in the ST8130 Series are the ST8130 and the ST8131.

Both models combine an analogue tachometer with a digital display for the following performance parameters:

1. Wheel speed
2. Engine speed (RPM)
3. Oil pressure
4. Oil temperature
5. Water temperature
6. Air temperature (optional)
7. Fuel level
8. Battery Voltage
9. Lap times (last completed and best) (optional)

You can view the peak values (tell-tales) for all the parameters.

Both systems provide an alarm light to alert the driver that a warning condition has been detected. The warning conditions are based on preset alarm values for the following performance parameters:

1. Oil pressure
2. Oil temperature
3. Water temperature
4. Air temperature / Ice warning -The unit is delivered with the air temperature alarm disabled.
5. Fuel level -The fuel level alarm is indicated by a separate warning light. The unit does not display any message for the fuel level alarm.
6. Battery voltage

When the warning condition alarm light is switched on, a warning message is shown on the digital display to identify the condition. You can enable or disable the warning system for each parameter individually.

You can cancel the warning message by pressing a switch. Doing this does not turn off the warning condition alarm light, which stays on until the condition no longer applies.

You can redefine the preset alarm value for each parameter to a value that is more suitable for your vehicle.

The system provides outputs for two external warning lights:

- a gear shift warning light that is based on an RPM value that you define for your vehicle
- an additional alarm warning light for the alarms described above

Either model can also be fitted with an optional lap timing sensor or an optional air temperature sensor.

ST8130 Model

The ST8130 model is used in conjunction with the ST492 pulse amplifier. This system obtains the vehicle's speed from pulses generated by the rotation of the vehicle's drive shaft or from the gear box.

ST8131 Model

The ST8131 model is used in conjunction with the ST670 wheel speed sensor. It obtains the vehicle speed from the rotations of one of the wheels on the vehicle.

How to Use this Manual

Stack recommends that you unpack and connect the components in the system **before** you install it in your vehicle. This will enable you to familiarise yourself with operating the display and configuring it for the vehicle in which you intend to install it.

This manual starts by taking you through the process of setting up the system before installation, operating the digital display, configuring the

system and setting the alarm values, and installing it in the vehicle. By the end of chapter 2, you will have set up the system so that you will be assured that it is functioning normally. You can then read chapter 3 and practice using its functions. Chapter 4 takes you through configuring it for your vehicle. Chapter 5 explains how to install it in the vehicle. Chapter 6 provides a set of trouble-shooting guidelines.

A full size template for the dashboard cut-out for the ST8130/31 systems is provided in Appendix A and a schematic diagram of the wiring harness is in Appendix B.

Chapter 2. Getting Started

This chapter guides you through the initial unpacking and setting up of the equipment for pre-installation checks and familiarisation with its operation.

Standard ST8130 Road Car Display System Items

The ST8130 Road Car Display System is supplied with the following standard components:

Quantity	Description
1	Display Module (ST867) with 2 mounting brackets
1	Wiring Harness (ST872)
1	Pressure Sensor (ST744 (UK, EU) ST745 (USA))
2	Oil/Water Temperature Sensors (ST762 (UK, EU) ST764 (USA))
1	Pulse amplifier (ST492) and extension leads
4	Switches (supplied with and to be connected to the wiring harness)

Standard ST8131 Road Car Display System Items

The ST8131 Road Car Display System is supplied with the following standard components:

Quantity	Description
1	Display Module (ST867) with 2 mounting brackets
1	Wiring Harness (ST872)
1	Pressure Sensor (ST744 (UK, EU) ST745 (USA))
2	Oil/Water Temperature Sensors (ST762 (UK, EU) ST764 (USA))
1	Wheel speed sensor (ST670)
4	Switches (supplied with and to be connected to the wiring harness)

Optional ST8130/ST8131 Road Car Display System Items

The optional air temperature sensor consists of the following component:

Quantity	Description
1	Air Temperature Sensor (ST765)

The optional lap timing system consists of the following components:

Quantity	Description
1	Infra-red lap beacon (ST544)
1	Lap timing receiver (ST543)

The Display Module

The Display Module consists of an analogue tachometer, two indicator lights, and a digital display panel.

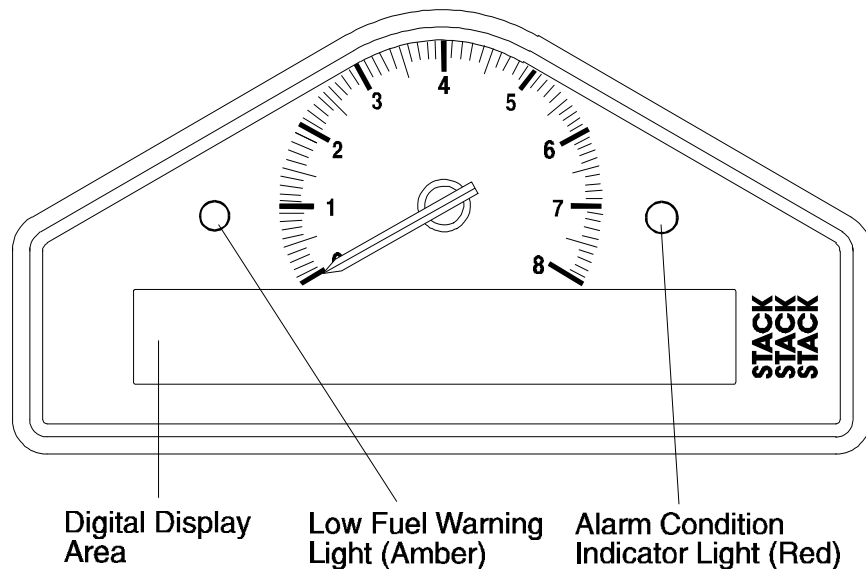

The Display Module is connected to a variety of sensors by a wiring harness. The wiring harness has a 19-way military connector for connection to the Display Module.

Wiring Harness

Each of the wires in the harness is labelled.

Labels on short cables	Connection To
S1 to S4	Switches 1 to 4
WS	Wheel speed sensor (ST8130) or pulse amplifier (ST8131)
SL	Gear shift warning light
AL	Alarm warning light
NET	Data logging expansion pack
LAP	Optional in-car lap timing sensor

Labels on Long Cables:	Connection To
A	Optional Air Temperature sensor
ES	Engine Speed (RPM)
OT	Oil temperature sensor
WT	Water temperature sensor
OP	Oil pressure sensor
F	Fuel level sensor
B +	12v Supply (Battery)
B -	Battery negative (Chassis)

Connecting the Components

1. Connect the wiring harness to the display module.
2. Connect the four switches to the cables labelled S1 to S4.
3. Connect each of the sensors that you have purchased to the appropriate wire in the wiring harness, as shown above.
4. Connect a 12v DC power supply or battery to the power input cable. **Never** use a battery charger to supply power to the display module.
5. Switch on the 12v DC power supply.

The Display Module should start up with an alarm signal indicating low oil pressure.

Note that whenever a warning message is shown on the top line of the digital display, the speed of the vehicle always continues to be shown in the centre of the bottom line.

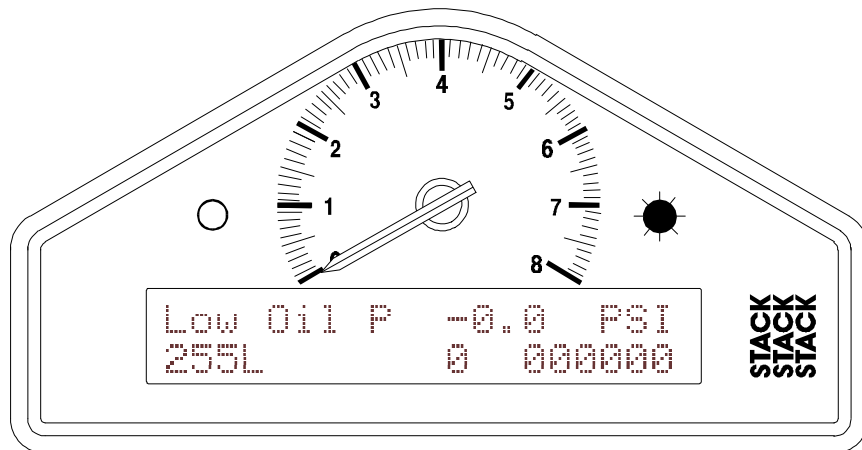

You can now proceed to familiarise yourself with operating the Display Module.

Chapter 3. Operating the Display System

This chapter takes you through the operation of the system so that you can familiarise yourself with its use before you install it in the vehicle.

Switching the Display System on

You will have switched the system on already if you have followed the instructions in the previous chapter and have just set the system up for the first time before installing it.

When installed in the vehicle, the system is switched on when you switch the ignition on.

When the power is first switched on, the digital display will immediately show a "Low Oil P" warning and the alarm light will come on. The tachometer will reset itself by moving the needle until it touches the stop-pin, and then moving it back to the zero RPM position. Press Switch 3 to clear the warning message from the display. (Switch 2 can also be used for this.)

The digital display panel and the analogue dial face are always backlit when the system is switched on.

If none of these actions occurs when you switch on, switch off the power to the system and consult the section on troubleshooting in this manual.

Changing the display layers

The digital display has five display layers. Each display layer shows three parameters and their values

Each of the display layers is displayed in turn by pressing switch 3. Press switch 3 when display layer 5 is being displayed in order to return to display layer 1.

⇒ **The format of the values in these displays will vary for systems supplied outside the UK, as the parameters are displayed in different units.**

Display Layer 1

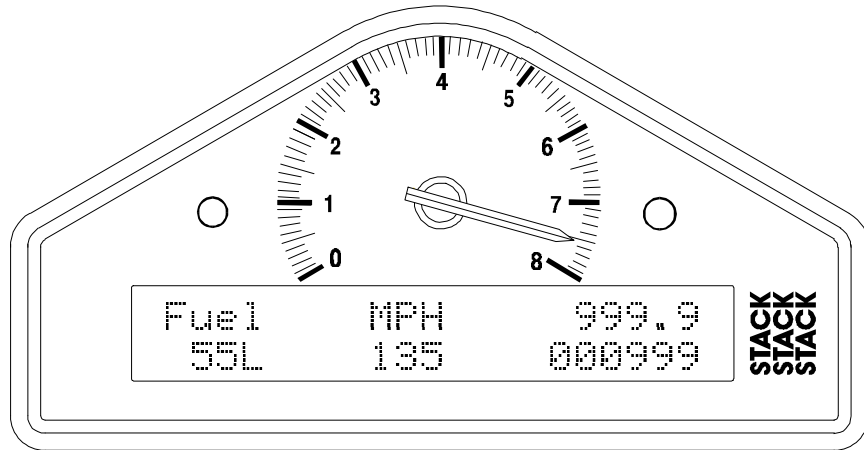

Display layer 1 shows:

- Fuel level (Note when the amount of fuel in the tank is changed that the displayed value changes slowly ~1ltr/5sec.)
- Current speed (MPH or km/h)
- Trip indicator
- Odometer

Note that when the UK version has the speed shown as km/h, the trip and odometer continue to display distances as miles.

Press Switch 3 to see display layer 2.

Display Layer 2

Oi I T	MPH	Oi I
P		
110 C	135	90

Display layer 2 shows:

- Oil temperature (Oil T)
- Current speed (MPH or km/h)

- Oil pressure (Oil P)

Note that the minimum oil and water temperature for which the display gives a true reading is 12°C or 53°F. The unit displays temperatures that are less than this as 0°C or 32°F.

Press Switch 3 to change display to layer 3

Display Layer 3

Water P	MPH	Oi l
75 C	135	90

Display layer 3 shows:

- Water temperature
- Current speed (MPH or km/h)
- Oil pressure (Oil P)

Press Switch 3 to display layer 4.

Display Layer 4

Ai r	MPH
Batt 5C	135
12. 6V	

Display layer 4 shows:

- Air temperature (Air) (optional)
- Current speed (MPH or km/h)
- Battery Voltage (Batt)

Press Switch 3 to change the display either to layer 5 if you have the lap timing kit installed or back to layer 1.

Display Layer 5

Lap 12	MPH
Best	
1: 35. 10	135
1: 35. 06	

Display layer 5 shows:

- Number of the current lap
- Current speed (MPH or km/h)
- Last lap time
- Previous best lap time

Press Switch 3 to change the display back to layer 1.

Lap time can be recorded manually using Switch 4 or with the optional lap timing kit.

Peak Values (Tell Tales)

The system can display the peak values (sometimes called 'tell-tales') that have been recorded during a run for all the monitored parameters.

Peak values are updated only when the engine speed has exceeded its "gate value" for RPM *for at least one second*. This allows the values to stabilise. Blipping the engine may not be enough to update the peak values. The gate value is a predefined RPM value that is used to control when the system updates the peak values. This is to prevent abnormal peak values from being recorded when, for example, the engine is either not running, is idling, or is being warmed up.

The system stores either a maximum or a minimum value as the peak value, depending on the parameter, as in the following table:

Parameter	Type of Peak Value	Gated to RPM
Engine Speed (RPM)	Maximum	No
Oil Temperature	Maximum	Yes
Water Temperature	Maximum	Yes
Oil Pressure	Minimum	Yes
Fuel Level	Value @ Reset	No
Battery Voltage	Minimum	No
Air Temperature (Ice Warning)	Minimum	No
Wheel Speed	Maximum	No

Displaying the Peak Values

Press and hold **Switch 1** to show the peak values for the parameters currently being displayed. Release the switch to return to the normal display.

Note: The displayed peak fuel level is the value that was current when the peak values were last reset. The amount of fuel used since the peak value reset can be calculated by subtracting the current value from the peak value.

Resetting the Peak Values

You can reset all of the peak values manually. All peak values are reset at the same time. If the engine is running **at** or **above** its gate value when the peak values are reset, they are set to the current value of each performance parameter.

To reset the peak values:

- Press and hold Switch 1 to display the peak values.
- While holding Switch 1, press and hold Switch 4.
- With Switch 4 held down, you will see the display revert to the current values. The new peak values that are stored are those being displayed when you release Switch 4.

If the engine is running **below** its gate value, the peak values are not reset to the current values but are set to the values in the following table:

Parameter	New Peak Value
Engine RPM	Current value
Wheel speed	Current value
Oil Pressure	999 PSI or 99.9 Bar
Oil Temperature	0C or 0F
Water Temperature	0C or 0F
Air Temperature	Current value
Fuel Level	Current value
Battery Voltage	Current value

Peak Value Memory

The peak values are stored in a memory which is powered by an internal back-up battery. They remain stored in this memory when the external power source is disconnected from the system. The internal battery needs to be changed every 4-5 years. When the power from this battery drops below a safe level, an alarm is triggered and the warning "Internal Battery Low" is displayed.

Alarms

The Display System has built-in warnings to alert the driver when certain parameters either exceed or fall below their alarm values. For example, a warning is signalled if the oil pressure falls below its alarm value or if the oil temperature rises above its alarm value. You can adjust the preset alarm levels when you configure the Display System. See Chapter 4, *Configuring the Display System* in this manual.

Some of the warnings (see the following table) are triggered only after the engine speed has exceeded its "gate value" for RPM **for at least one second**. Blipping the engine may not be enough to trigger a warning. The gate value is a predefined RPM value that is used to control when the system is to trigger a warning. This is to prevent abnormal warnings

from being triggered when, for example, the engine is either not running, is idling, or is being warmed up. Once the engine has been running above the gated RPM for one second, any problems will trigger an **immediate** warning.

(The oil pressure alarm will come on at power-up until the engine is started and pressure exceeds the threshold set for the alarm.)

The Display System has the following built-in alarms:

Parameter	Alarm is triggered when the:	Gated to RPM
Oil Temperature	current value exceeds the preset value	Yes
Water Temperature	current value exceeds the preset value	Yes
Oil Pressure	current value drops below the preset value	No
Fuel Level	current value drops below the preset value	No
Battery Voltage	current value drops below the preset value	No

Displaying an Alarm

When an alarm condition occurs, the built-in red warning light turns on, and the digital display gives a warning message to show the type of alarm:

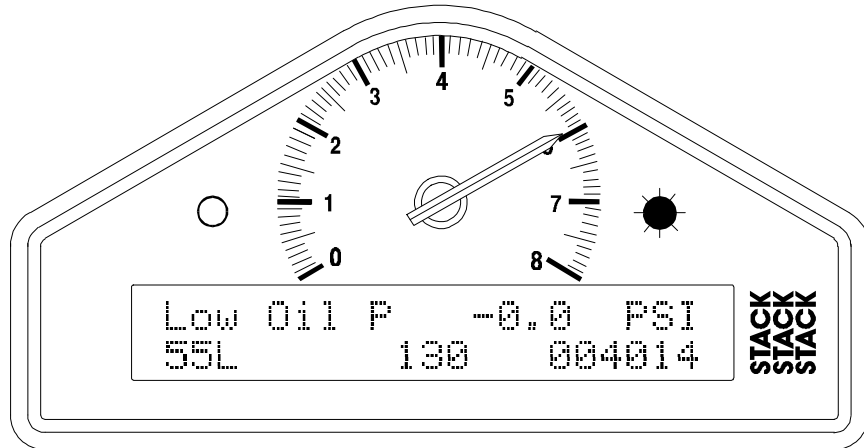

Note that the low fuel warning is indicated by the amber light.

Clearing an Alarm

Press Switch 2.

Showing the Last Alarm

Press and hold Switch 2.

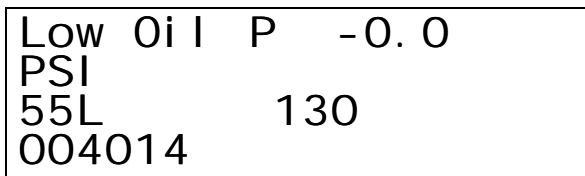

Lap times

The lap time for each lap is recorded either by the infra-red lap time sensor when passing the lap time beacon or when the driver presses Switch 4.

The most recent lap time is held in display layer 5. Press Switch 3 to see this display layer. This display gives you time of the last recorded lap and the lap number of the current lap.

Lap	12	MPH	
Best			
	1: 35. 10	135	
	1: 35. 06		

Resetting the Lap Time to Zero

Press and hold Switch 1 and then press Switch 4 to reset the lap count and lap time to zero. The lap timer starts recording the time immediately.

Lap	0	MPH	Best
	0: 00. 00	0	0: 00. 00

Gear shift light

The optional external gear shift light comes on when the engine RPM exceeds a predefined value. See "Configuring the Display System" for information about setting this value.

Chapter 4. Configuring the Display System

Configuration mode

You put the Display System into configuration mode by pressing Switches 1 and 2 together. This should give a display similar to the following:

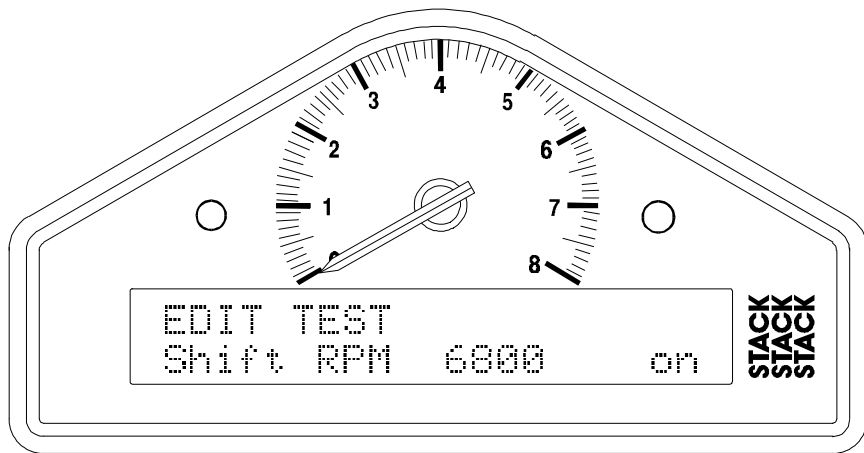

You then work through the configurable parameters in a preset sequence.

Press Switch 3 to display the next configurable parameter.

Press Switch 4 to end configuration mode.

Setting or resetting configuration values

Use Switch 1 to decrease the value being configured and Switch 2 to increase it. The rate at which the value increases or decreases itself increases while the switch is being held down.

Switching Alarms on or off

You can enable (switch on) or disable (switch off) each of the alarm warnings by pressing and holding Switch 1 and then pressing Switch 2.

Note that you might change the preset value of the parameter slightly while pressing both switches. This does not matter if you are switching the alarm warning off and, if necessary, you can correct the preset value after you switch it on again.

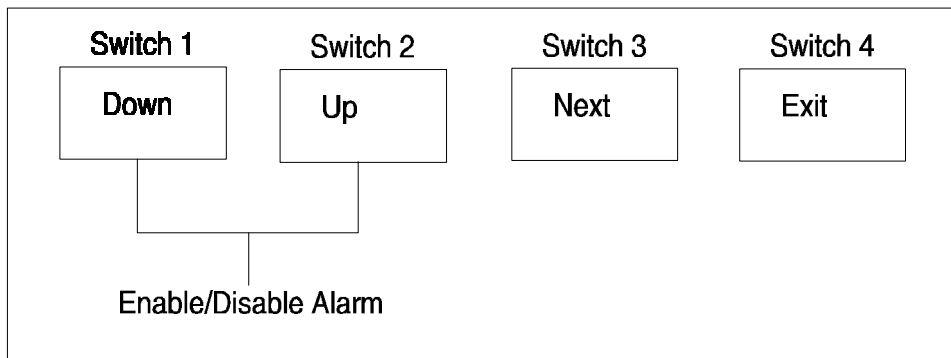

Summary of Configuration Switches

Configurable Parameters

The configurable parameters are displayed in the following order:

Configurable Parameter	Setting Required	Switchable Parameter
Shift RPM	RPM at or above which the gear shift light is to come on	Yes
Low Fuel	Volume of fuel in tank at or below which the low fuel warning light is to be turned on.	Yes
Ice Warning	Air temperature at or below which the Ice Warning alarm is to be signalled	Yes
High Oil T	Oil temperature at or above which the High Oil T alarm is to be signalled.	Yes
High Water	Water temperature at or above which the High Water alarm is to be signalled.	Yes
Low Batt	Battery voltage at or below which the Low Batt alarm is to be signalled.	Yes
Low Oil P	Oil pressure at or below which the Low Oil alarm is to be signalled.	Yes
Fuel Tank Sender	The volume of fuel currently in the tank. See "Calibrating the Fuel Level", below, for more details.	Not Applicable
Gate RPM	Minimum RPM for oil temperature, oil pressure, and water temperature warnings to operate.	Yes
E. S. Cylinders	Number of cylinders in engine (for RPM)	Not Applicable
W.S. Pulses/Rev	See "Wheel Pulses and Circumferences" later in this chapter for an explanation of how to calculate the value to be used.	Not Applicable
Wheel Cir (mm) (ins)	See "Wheel Pulses and Circumferences" later in this chapter for an explanation of how to calculate the value to be used.	Not Applicable

Examples of the displays for each of the configuration items are shown below.

Shift RPM:

EDIT TEST	
Shift RPM	7000
on	

Low fuel:

EDIT TEST	
Low Fuel	10L
on	

Air Temperature:

EDIT TEST	
Ice Warning	- 7C
on	

High oil temperature:

EDIT TEST	
High Oil T	130C
on	

High water temperature:

EDIT TEST	
High Water	105C
on	

Low battery voltage:

EDIT TEST	
Low Batt	10.0
on	

Low oil pressure:

EDIT TEST	
Low Oil P	35
on	

Fuel Level Calibration:

SW1 & 2 to	
calibrate	
Fuel Tank Sender	

Gate RPM:

EDIT TEST	
Gate Revs	3000
on	

Engine speed cylinders:

E. S. Cylinders	4
-----------------	---

Wheel speed pulses:

W. S. Pul ses/Rev 10

Wheel circumference:

Wheel Ci r (mm) 1000

Wheel Pulses and Circumferences

Calculations for the ST8130 (ST492 Pulse Amplifier)

You must supply a value for the wheel circumference that you obtain from one of the following calculations:

1. If you know the number of pulses generated for one mile (US version only):

$$63360, \text{ pulses per mile} = \text{wheel circumference}$$

(Set the number of pulses per rev to 1.)

Note: If the resulting circumference is less than 20.0 inches, double this value and set the number of pulses per rev to 2. This is to make the calculated speed and distance as accurate as possible.

Example:

Pulses per mile: 5000

$$\text{Circumference} = 63360 \div 5000 = 12.67 \text{ inches}$$

Double the two values:

$$\text{Wheel Cir (ins)} = 25.3 \text{ inches}$$

$$\text{W.S. Pulses/Rev} = 2$$

2. If you know the number of pulses generated for one kilometre (UK/EU version only):

$$1000000, \text{ pulses per km} = \text{wheel circumference}$$

(Set the number of pulses per rev to 1.)

Note: If the resulting circumference is less than 500mm, double this value and set the number of pulses per rev to 2. This is to make the calculated speed and distance as accurate as possible.

3. If you know the number of pulses generated for one mile (UK/EU version only):

$$1609344, \text{ pulses per mile} = \text{wheel circumference}$$

Set the number of pulses per rev to 1.

Note: If the resulting circumference is less than 500mm, double this value and set the number of pulses per rev to 2. This is to make the calculated speed and distance as accurate as possible.

Example:

Pulses per mile: 5000

$$\text{Circumference} = 1609344 \div 5000 = 321.9\text{mm}$$

Double the two values:

$$\text{Wheel Cir (mm)} = 644\text{mm}$$

$$\text{W.S.Pulses/Rev} = 2$$

4. If the pulses are coming from the wheel, i.e. you know the number pulses for each revolution of the wheel. Enter the actual circumference and the number of pulses per revolution (see the following section)

Calculations for the ST8131 (ST670 Wheel Sensor)

You must supply a value for the wheel circumference that you obtain from one of the following calculations:

1. If the sensor is mounted on a wheel, set this value to the circumference of the wheel and set the number of pulses per revolution to number of targets on the wheel.

Note: If the circumference is less than 500mm or 20.0 inches, double both this value and the number of pulses per revolution. This is to make the calculated speed and distance as accurate as possible.

If the sensor is mounted on a driveshaft or the propshaft, set the circumference to:

Actual wheel circumference ÷ differential ratio
-where the differential ratio is calculated as:
crownwheel (ring) teeth , pinion teeth

Note: If the resulting value is less than 500mm or 20.0 inches, double both this value and the number of pulses per revolution. This is to make the calculated speed and distance as accurate as possible.

Set the number of pulses per revolution to the actual number of pulses per revolution of the shaft.

Examples for 9 pinion teeth & 41 crownwheel (ring) teeth:

UK/EU

Differential ratio: $41 \div 9 = 4.55$
Pulses per revolution: 4
Tyre circumference: 1800mm
Circumference = $1800 \div 4.55 = 395\text{mm}$

Double the two values:

Wheel Cir (mm) = 790mm
W.S. Pulses/Rev = 8

US

Differential ratio: $41 \div 9 = 4.55$
Pulses per revolution: 4
Tire circumference: 70.9 inches
Circumference = $70.9 \div 4.55 = 15.6\text{ inches}$

Double the two values:

Wheel Cir(ins) = 31.2 inches
W.S. Pulses/Rev = 8

Calibrating the Fuel Level

To calibrate the fuel level reading with the actual amount of fuel in the tank, you will need to start with a tank that contains the amount of fuel you require for its reserve and progressively fill it with known quantities of fuel. While filling the tank, you must use at least two and possibly as many as ten (the maximum permitted) calibration points to set values for accurate fuel level readings. More than five calibration are recommended, with the first at zero (empty) , the second at five litres, the third at ten litres, and the remaining points divided equally across the amount of fuel still required to fill the tank completely.

Use the following procedure:

Set the Display System to configuration mode.

1. Decide how many calibration points and the amount of fuel for each that you are going to use. For example, to calibrate the readings for a 50 litre (10 gallon) tank for the following quantities, the following seven calibration points are suggested: 0, 5L (1gal), 10L (2gal), 20L (4gal), 30L (6gal), 40L (8gal), 50L (10gal).

For a 100L (20gal) tank, ten calibration points are suggested: 0, 5L (1gal), 10L (2gal), 20L (4gal), 30L (6gal), 40L (8gal), 55L (11gal), 70L (14gal), 85L (17gal), 100L (20gal).

Empty the tank so that it contains only the amount you require as its reserve. Use the fuel pump to empty the tank. Add the reserve fuel, for example, two litres (0.5 gal.).

You may wish to enter these values into the table on p30. If you ever have to return the unit for servicing, supplying the values from this table will allow Stack to automatically recalibrate the fuel display so that you will not have to repeat this process.

You should now drive to your local petrol (gas) station a fill the car on level ground in order to complete the calibration process.

To make the calibration process more efficient it is recommended that you have one person to operate the petrol (gas) pump & one person to operated the switches for the Dash.

Note: The petrol (gas) pumps may shut off, if the petrol delivery is interrupted for a time.

2. Select the Fuel Tank Sender calibration display.

Hold Switch 1 down and press Switch 2. This gives a display similar to the following:

Tank Qty	OL
Reading	255

3. Use Switches 1 and 2 to change the Tank Qty value to zero if it is not already zero. Switch 1 decreases the value shown while Switch 2 increases it. Note the Tank Qty and the Reading value in the table on p30.

When you have set the Tank Qty to the required value, press Switch 3 to set this value.

4. Press Switch 1 to continue to the next calibration point.
5. Fill the tank with a small, known amount of fuel, for example, five litres (one gallon). If the Reading value does not change, there is a problem with either the fuel sender or the wiring.
6. Wait for the Reading value to stabilise. This requires several seconds. While you are waiting for the Reading value to stabilise, use Switch 1 and Switch 2 to change the Tank Qty value to the amount of fuel now in the tank.
7. When the Reading value has stabilised, press Switch 3 to set this value
8. Repeat steps 6 through 9 above for each calibration until the tank is full or you have performed at least two or as many as ten calibration operations.
9. Press Switch 2 (Finished) when you have completed calibrating the fuel level readings.

You can press Switch 4 to go to the cancel calibration mode, then Switch 1 to Cancel, or Switch 2 to Continue with calibration.

Cancelling the calibration leaves the original calibration set.

The flowchart on the next page summarises the steps in the calibration process.

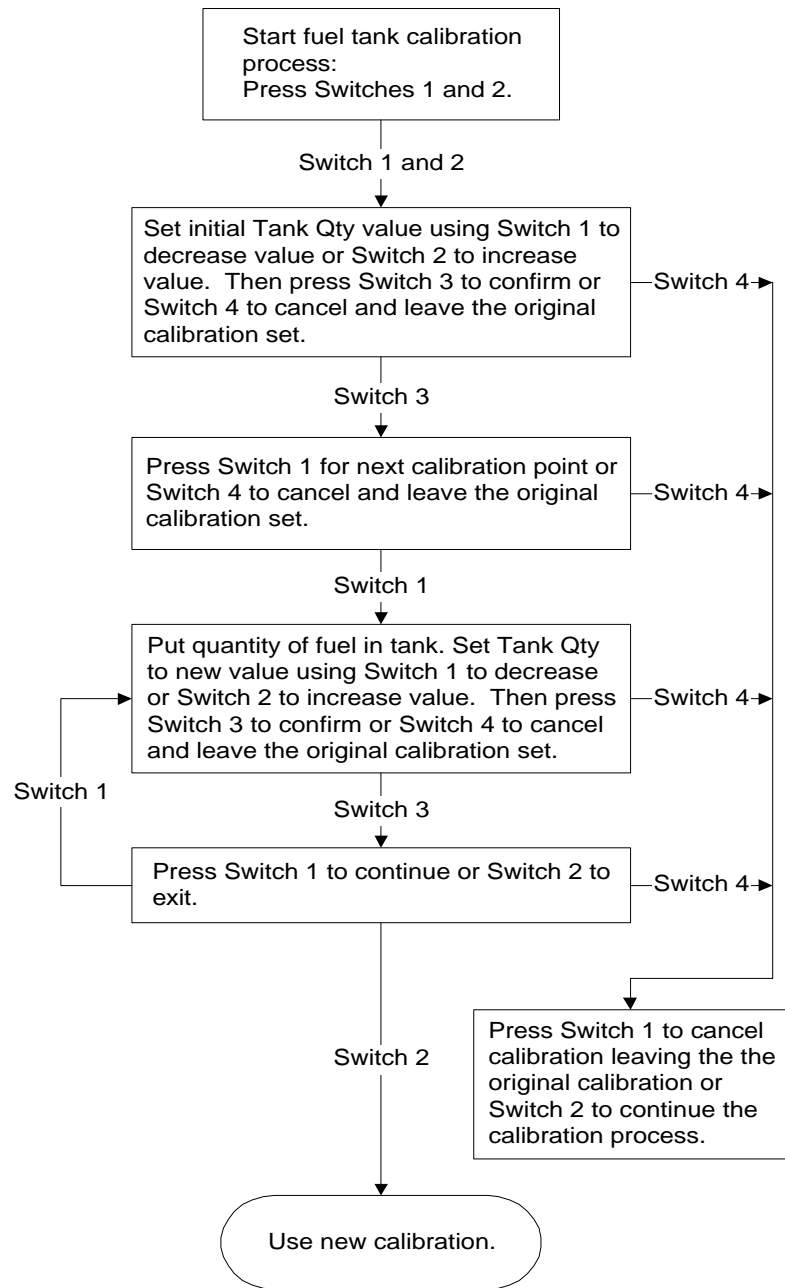

If the displayed reading values do not change by a significantly large amount from the empty to full condition, the fuel level sender in your vehicle may not be suitable for use with the ST8130 or ST8131 Road Car Display System. Check with your Stack dealer if this is the case.

When you wish to return to the normal display, press Switch 4.

Fuel Calibration Table

	Fuel Qty	Reading
1		
2		
3		
4		
5		
6		
7		
8		
9		
10		

Chapter 5. Installing the Display System

Who can install the Display System?

The Display System can be installed by anyone competent in fitting electrical and mechanical accessories to cars.

Tools needed to install the Display System

ST8130

A trimmer tool or small flat jeweller's screwdriver (1.5mm or 1/16 inch blade) is required in order to adjust the pulse amplifier.

ST8131

No special tools other than normal workshop tools are needed.

Preconfigured Display Systems

Use the instructions in the previous chapters to set up, operate, and configure the ST8130 or ST8131 before installing it in the vehicle.

Custom Configured Display Systems

If you have purchased a Display System that has been custom configured for you, the system may include components not described in this manual. Refer to the additional instructions supplied with the system for such components.

This manual may refer to components not included in the system. You should ignore them.

Fitting the Display Module

The Display Module is fitted into a cut-out in the instrument panel/dashboard and secured using the two U-brackets at the rear. The dimensions for the cut-out are shown below. A full size template is supplied at the end of this manual.

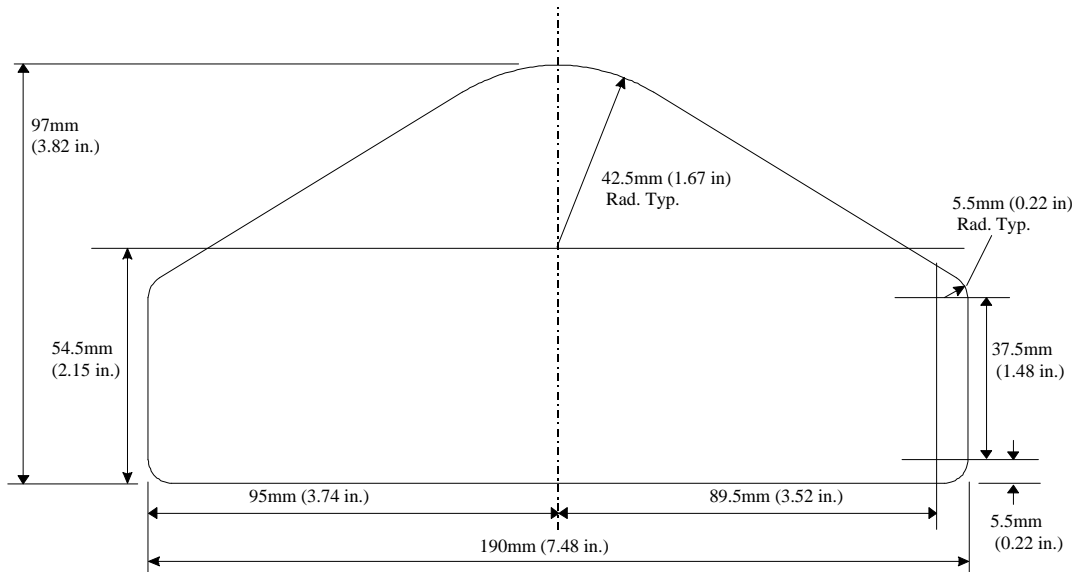

Positioning the Display Module

Ensure that there is sufficient space behind the cut-out to allow the wiring harness to be connected to the 19-way connector without any tight bends to the wiring near the connector.

The Display Module must be positioned on the dashboard so that the driver can see it, either over the steering wheel or through it.

The Display Module should be aligned so that the driver looks at it square or from slightly above or below.

Switches

The four switches are used to control the functions of the Display System.

The normal functions of the four switches are:

Switch	Functions
Switch 1	Show the peak values.
Switch 2	Clear an alarm and show the last alarm.
Switch 3	Change the display layer and clear an alarm.
Switch 4	Reset the trip distance to zero and start the lap timer. The trip distance is reset after each lap.
Switches 1 & 2	Set up mode.
Switches 1 & 3	Change speed units to MPH or km/h (UK version only).
Switches 1 & 4	Reset the peak values and lap times.

You can install the switches in any convenient location. When installing the switches, you should take account of the following considerations:

- The cable for each switch is approximately 400mm/16" in length from the 19-way military connector.
- It is important that the driver is able to reach Switch 3 easily in order to change the display and clear warning messages after alarms. This switch can be fitted on the steering wheel.
- When you configure the system, you use Switches 1 to 4 for selecting the parameters and setting their values. These switches should be installed so that you can reach them easily when you are viewing the digital display.

Warning lights

The Display Module has two built-in warning lights. The left-hand (amber) light is the fuel level warning light and the right-hand (red) light alerts the driver whenever an alarm has been triggered.

As an option, you can install additional external warning lights for gear shift and alarm warnings. The external warning lights should be installed in any position that is in the driver's direct line of vision, as they need to be visible at all times.

Stack Ltd can supply suitable external warning lights for installation in the dashboard (ST536/537) as well as shrouded versions that can be mounted on top of the dashboard (ST533/534).

- ⇒ **If you are using your own warning lights, ensure that the bulb rating does not exceed 2 Watts; otherwise the Display Module will be damaged. If you need to use lamps greater than 2W, connect them to relays and use the output sockets from the Display Module to switch these relays.**

Engine Speed (RPM) Measurement

The engine speed (RPM) is measured by connecting the engine speed wire directly to the ignition system. A single wire, with the label ES, connects the Display System to the ignition system or low-tension side of the coil.

Connecting the Display System to the Ignition System

The Display System can be connected to engines with a variety of ignition systems. These are shown in the following table.

Ignition System	Normally Fitted To	Connection Point
Bosch	Citroen AX 'Sport' and 'GT'	Tachometer output (coil negative) with 100K series resistor
Bosch 3-pin CD	Porsche 911 Carrera '76	Pin 'C' (points connection)
Bosch 8-pin CD	Porsche 930 Turbo '76	Pin 7 on ignition unit
General Motors GME-071	Vauxhall Opel	Tachometer output (coil negative) with 10K series resistor
Lumenition Performance (Black)	Accessory only	Blue wire from distributor pick-up
Lumenition Optronic MK17 (Silver)	Accessory only	Brown wire on coil negative
Motorcraft	Ford	Coil negative with 47K series resistor
Performance Coil (Bosch Blue Coil)	Accessory only	Coil negative with 47K series resistor (use screened high tension leads)

The following connections are shown in greater detail:

- Standard contact breaker system
- Series Resistor Connection

The connection of the Display System to these types of ignition system is described below:

Standard contact breaker system

Connect the ES (Engine Speed) wire to the negative terminal on the coil.

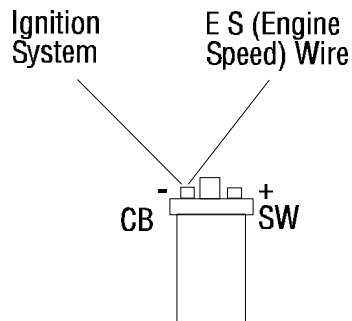

Series Resistor Connection

For systems which require series resistor on the ES (Engine Speed Wire) the resistor must be connected directly to the terminal to limit interference from the high tension leads (which must be the screened type).

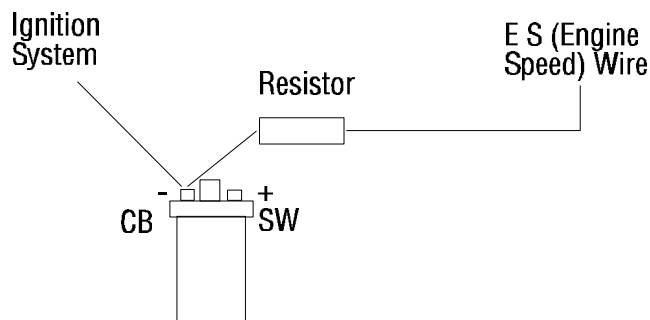

Pressure sensor

Fitting the pressure sensor

The Display System is supplied with one of the following types of pressure sensors: the Stack ST744, the ST745, or the ST746.

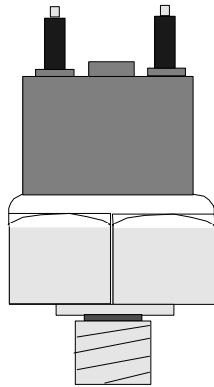

The ST744 pressure sensor has an M10 x 1 thread (UK, EU).

The ST745 pressure sensor has a 1/8" NPTF thread (USA).

The ST746 pressure sensor has a 1/8" BSP thread.

Each of the above types of sensor is used for monitoring the oil pressure.

Installing the pressure sensor

- Position the sensor and its cable as far as possible from all sources of intense heat and from the ignition HT leads.
- The sensor can be either screwed in directly to the monitoring point or fitted separately by using a suitable pressure hose to connect it to the monitoring point. **By fitting the sensor separately, you will reduce the amount of vibration to which it is subjected and thereby extend its life.**
- Do not over-tighten the sensor.

Temperature sensors

The Display System is supplied with two each of one of the following types of temperature sensor: Stack ST760, ST761, ST762 or ST764:

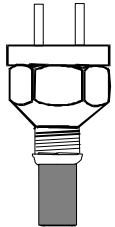

ST760 has a 1/8 BSP (Taper) thread

ST761 has a M14 x 1.5mm thread.

The ST762 temperature sensor has an M10 x 1 thread (UK, EU versions).

The ST764 temperature sensor has two terminals and a 1/8" NPTF thread (U.S. version)

Each type of sensor can be used for monitoring both oil temperature and water temperature.

If you find that you have a sensor with an incorrect thread, please return it to Stack for replacement.

Fitting the temperature sensors

Mount each temperature sensor directly in the appropriate fluid line. Screw the sensor into a suitable mounting boss, so that its end lies in the middle of the flow of fluid.

- Position the sensors and their cables as far as possible from sources of intense heat and from the ignition HT leads.

Wheel speed sensor

The ST8131 Display System is supplied with one Stack ST670 proximity sensor as a standard feature which must be fitted if the vehicle is to comply with the legal requirement for an on-road speedometer. This sensor is used to measure wheel speed in order to display the vehicle's speed in MPH or km/h. The sensor provides an electrical pulse to the system each time a ferrous object, such as a wheel bolt, passes near to the end of the sensor. When you configure the system, you will need to supply the circumference of the wheel and the number of ferrous objects that will be counted for each revolution of the wheel. If you are not sure whether the object you have chosen to use is ferrous, you can check it with a magnet. If there is no attraction, the object is not ferrous.

Fitting the wheel speed sensor

- Locate a suitable position for the wheel speed sensor so that one or more ferrous objects (such as bolt heads) will pass the end of the sensor as the wheel turns.
- If possible, choose the wheel that incurs the least amount of wheel spin, wheel lift, or lock-up, as these will affect the speed reading.
- Avoid mounting the sensor too close to the brake disc to avoid excessive heating.
- Make a suitably rigid bracket for the sensor and fit it onto the vehicle. Fit the sensor to the bracket.
- Do not over-tighten the sensor.
- Adjust the distance between the end of the sensor and the target ferrous object(s), so that the gap is $1.5\text{mm} \pm 0.5\text{mm}$ / 60thou \pm 20thou. Make sure that no other objects pass within 4mm / $5/32$ " of the end of the sensor while the wheel rotates.
- Once the system is powered up, a small LED built into the back of the sensor will light up each time a ferrous object passes within the defined distance from the end of the sensor.
- Position the sensors and their cables as far as possible from sources of intense heat and from the ignition HT leads.

Pulse Amplifier Interface (ST492)

Introduction

This amplifier is designed to convert the output of an existing sensor, which generates a pulsed signal which is not compatible with the ST8130 system's channel input requirements. This incompatibility may be caused by insufficient voltage or lack of output current drive capability.

The amplifier has negligible loading effect on the signal and includes the facility to adjust its sensitivity, so can be used with a wide variety of sensors.

N.B. For reasons of safety, NEVER connect the amplifier to an ABS speed sensor.

Installation

Mechanical

The amplifier should be mounted, using the self-adhesive dual locking material supplied, in a position away from strong sources of heat and H.T. leads. It should be noted that this adhesive will not reach full strength for up to 24 hours.

On one side of the module there is a small red LED and a potentiometer access hole. This potentiometer is used to alter the sensitivity and the LED is used to give visual confirmation of correct adjustment. Access to this part should therefore be considered when choosing a mounting position.

Using the 'dual-lock' fastener with Stack sensors

This is a high opening force 'Velcro-type' fastener system with identical mating halves. It is intended to be used for semi-permanent fixing applications, and is not intended for frequent dismantling.

For best performance, the following precautions should be taken:

Bond strength is dependent upon the amount of adhesive to surface contact development. Firm application pressure develops better adhesive contact and thus improves bond strength.

To obtain maximum adhesion, the bonding surfaces must be clean, dry and well unified. Typical surface cleaning solvents are isopropyl alcohol/water mixture (rubbing alcohol) or heptane. Use proper safety precautions when handling solvents.

Ideal application temperature range is 21-38°C (70-100°F). Initial application to surfaces at temperatures below 10°C (50°F) is not recommended because the adhesive becomes too firm to adhere readily.

To mount a sensor or housing on the vehicle

Take one of the supplied pieces of 'dual-lock' fastener, remove the adhesive backing, and attach to the sensor or housing.

Take a second strip of the fastener and attach to the first piece by pushing them together firmly, ensuring correct alignment.

Remove the adhesive backing off the second strip of fastener and attach the sensor or housing to the vehicle in the desired position. Push against the fastener firmly to ensure maximum adhesion.

Do not try to separate the 2 strips of fastener immediately

The acrylic adhesive backing should be given 24 hours to achieve full bond strength.

If you require further fastener strip, or have any comments, questions, or recommendations regarding its use, please contact Stack or your nearest distributor.

Electrical

The amplifier connects into the ST8130 system via a four way Mini Sure Seal (MSS) socket, the larger of the two connectors on the amplifier. Use the extender cable with an MSS connector at each end to connect the amplifier to the WS input on the harness.

The plug, the smaller of the two connectors on the amplifier, is the connection to the sensor. Use the cable with an MSS connector at one end and two wires at the other to connect the amplifier to the speed sensor.

For a two wire sensor, connect sensor wires to the red and black wires on the cable.

For a single wire sensor, connect the sensor wire to the red wire on the cable.

Adjustment

Once the system has been fully wired power should be applied.

At this stage it is desirable to arrange for the sensor to generate a low frequency signal by spinning the wheel slowly. The red LED at the end of the amplifier should be seen to flash as each signal is received. If the frequency is higher than approximately 10 flashes/second the LED may only appear to dim, as the flashing is too fast for the eye to see.

If this does not happen (the LED is always on or off) it will be necessary to adjust the input sensitivity of the amplifier to match the sensor. This is accomplished by turning the small screw head which is recessed in the hole adjacent to the LED. This should be adjusted until the LED flashes consistently.

The operation should be checked at the lowest possible frequency, as this is the most likely speed for problems to occur.

Following these adjustments, correct operation can be verified by observing the LCD speedometer at a range of speeds.

ST492 Technical Specification

Supply :	From ST8130 input
Output characteristics :	ST8130 compatible
Input impedance :	>50K Ohms
Operating temperature range :	-20 to +80 °C / -4 to 176 °F
Input threshold adjustment range :	-5 Volts to +12 Volts
Input hysteresis :	+/- 0.1 Volt
Maximum input frequency	2000 Hertz
Physical dimensions :	(mm) L 51, H 18, W 32 (in) L 2, H ¾, W 1¼
Weight :	50g / 2oz maximum
Vibration testing :	20 G, 50Hz to 2000Hz, 1 Octave/min for 12 hours

Fuel Tank Sender

Single-Wire Sender

If your vehicle is fitted with a single-wire sender (rheostat), remove the existing wire from it and connect the red (F) wire to it.

Two-Wire Sender

If your vehicle is fitted with a two-wire sender (potentiometer), remove the existing wires and fit the red (F) wire to one of the terminals. If there is no change in fuel-level reading during calibration, fit the red wire to the other terminal.

Lap timing sensor (optional)

The lap timing sensor is actuated by an infra-red beacon positioned at the side of the circuit. The sensor is fixed to a rigid bracket mounted at a convenient position on the outside of the vehicle where it is able to detect the signals from the beacon.

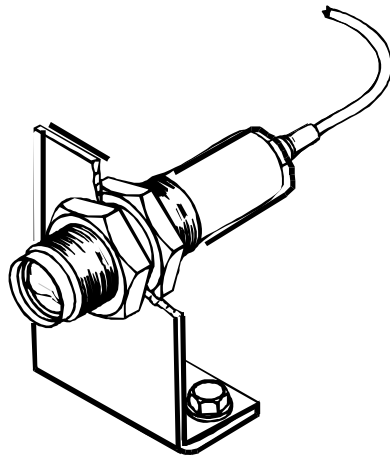

It is secured by two nuts (supplied) with an M18 x 1 mm thread.

This sensor must be positioned horizontally and square to the axis of the vehicle. In order to detect the signals from the beacon, it must be positioned outside the vehicle. It should, if possible, be positioned so that other vehicles that are being overtaken (or are overtaking) at the moment your vehicle passes the beacon do not block the signal.

Note that after detecting a signal, the system does not recognise any further signals from beacons for a period of ten seconds.

Trackside Infra-Red Lap Beacon (optional)

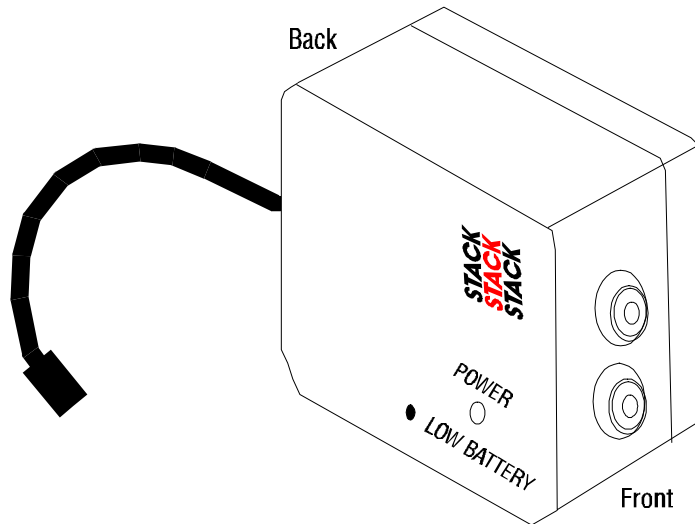

The ST544 trackside infra-red lap beacon should be located as follows:

- As near to the start-finish line as possible
- At the same height as the on-vehicle detector
- Level, so that it emits a horizontal beam
- It must be between 2 and 30 metres (6 and 100 feet) from the vehicle when the vehicle passes it

Avoid positioning it so that the sun is directly behind it when it is being used.

Where the unit is to be used for lengthy periods in very hot, sunny conditions, it should be protected by shading it from direct sunlight.

Do not allow water to be sprayed onto the transmitter lenses. During wet conditions, fit a protective shroud over the beacon.

Power supply to Trackside beacon

The beacon operates from a 12v DC supply. A sealed lead-acid battery with a minimum rating of 2.5 Amp/hour is recommended. This provides about 15 hours of operation.

The condition of the battery is indicated by the colour of the LED indicator on the front panel of the unit:

1. Green: The voltage is, at present, adequate for use
2. Red: The voltage is too low (replace the battery).
3. No Colour: Battery exhausted or disconnected.

Air Temperature Sensor (optional)

If you have the optional ST765 air temperature sensor, this must be connected to the A connector on the harness.

Instructions for fitting are supplied with the ST765.

When the sensor is installed, the Ice Warning alarm test should be enabled and set to an appropriate value - see Chapter 4. Configuring the Display System.

Wiring harness

The Display Module and the sensors, switches, and external lights for your Display System are connected together by means of the wiring harness supplied with the system.

The wiring harness can be fitted after the Display Module and all the sensors and switches have been installed.

This harness has been designed so that the various branches are long enough for most single seater and saloon cars. Occasionally, an individual branch may need to be extended or significantly shortened. If the standard harness is totally unsuitable for your vehicle, contact Stack for details of custom harnesses. Provided that you have chosen suitable locations for the switches, sensors, and any external warning lights that

you are installing, you should not need to extend any of the individual wires in the harness.

Extender wires for connecting the air temperature and wheel speed sensors to the wiring harness are available in the following lengths:

- 700mm / 2'3"
- 1400mm / 4'7"
- 2100mm. / 6'11"

The ST884 Kit contains the following extenders:

- two 700mm/2'3" extenders
- two 1400mm/4'7" extenders
- one 2100mm/6'11" extender

Fitting the wiring harness

When fitting the harness on the vehicle, you should observe the following:

- Start by attaching the harness to the Display Module by connecting the 19-way military connector.
- Position the ends of all the wires at the locations of the sensors, lamps, and switches to which each is to be connected, but do not connect them yet.
- All wires should be routed as far as possible, and not less than 50mm/2", from ignition HT leads and distributor caps, and any other sources of high voltages.
- When you pass any wire through a bulkhead or dashboard, fit a cable grommet or gland into the hole so that the edge of the hole cannot chafe the wire.
- Particular care is needed when passing wires through holes in carbon fibre, as the carbon can cut through cables very easily.
- The heatshrink sleeving around the sensor cables can be cut back, if necessary, to enable the sensor cables to go in separate directions earlier. It is recommended that you always leave at least 150mm/6" of heatshrink sleeving to provide additional strain relief for the cable where it enters the 19-way connector.

- Connect the wires when all the sensors are in position and you have secured the wiring harness.

Wiring labels

See Chapter 2 if you need to check the labels used to identify the individual cables in the wiring harness

Checks and Alarms

You should check the system to ensure that all the sensors are detecting the correct values. You should also run the engine at its operational levels to check that the values displayed by the Display System are accurate. You should then check out the alarm systems to ensure that they are functioning correctly before going out onto the circuit.

Chapter 6. Troubleshooting

No.	Symptom	Possible Cause	Remedy	Notes
1	Display is dead (no backlight, nothing on display, no green dial lights)	Ignition is off	Turn ignition on	B + is 19w connector pin G. The power lead B - is 19w connector pin H.
		Battery is dead	Recharge or replace battery	
		Power connection to B + or B - is faulty	Check if battery is connected correctly. Check power lead continuity	
2	Display is dead (no backlight, nothing on display, green dial lights on but dim) or Low Battery warning on display	Battery is almost dead	Recharge or replace battery	
		Power connection to B + or B - is faulty	Check power lead continuity	
3	Display flashes and dial pointer resets or vibrates	Battery is almost dead	Recharge or replace battery	
		Power connection to B + or B - is faulty	Check power lead continuity	

No.	Symptom	Possible Cause	Remedy	Notes
4	The Low Oil P message does NOT appear on power up.	Pressure sensor has failed	Replace sensor	
	The warning light is not turned on.	Sensor connections are faulty	Check for continuity on sensor lead.	A reading of 999 on the display indicates an open circuit connection (pin D to the red sensor lead and pin H to the black sensor lead)
		Oil pressure alarm disabled	Check that the oil pressure alarm is set on	
5	Display gives a fixed temperature reading of 999° C or 999° F	Temperature sensor has failed	Replace sensor	Disconnect sensor. If reading changes to 0, replace sensor.
		Faulty sensor connections	Check the continuity of sensor leads: with the sensor disconnected and the display powered up, there should be 6.25V between the sensor leads.	Otherwise check harness for short circuit

No.	Symptom	Possible Cause	Remedy	Notes
6	Water or Oil temperature display gives a fixed temperature reading of 0°C or 0°F when the water temperature is either above 12°C or 55°F	A temperature sensor has failed	Disconnect sensor and short its leads together. If the reading changes, replace the sensor	
	Air temperature display gives a fixed temperature reading of -99°C or -99°F when the ambient temperature is above -20°C or -4°F	Faulty sensor connections	Check continuity of sensor leads for open circuits. See No. 5 above.	Check the wiring harness for open circuits (pin E to the red OT sensor wire, pin P to the red WT wire, and pin H to both the black OT and WT sensor wires)
7	Fixed pressure reading of 999 PSI or 99.9 Bar	Pressure sensor has failed	Replace sensor	
		Faulty sensor connections	Check continuity of sensor leads for open circuits. See No. 5 above.	Pin D to the red OP wire and pin H to the black OP wire
8	Fixed pressure reading of -99 PSI or -9.9 Bar	Pressure sensor has failed	Replace sensor	Disconnect sensor. If reading changes to 999, replace sensor
		Faulty sensor connections	Check continuity of sensor leads for short circuits	Check the wiring harness for short circuit

No.	Symptom	Possible Cause	Remedy	Notes
9	Fixed pressure reading of 0 PSI or 0.0 Bar or suspected low/slow reading	Pressure sensor has failed	Replace sensor	
		Faulty sensor connections	Check pressure connections	Check plumbing for a blockage (kinks in flexible hoses)
10	All sensors show fixed high values	Switch 1 (Peaks) faulty	Replace switch	Disconnect switch. If values return to normal, replace switch.
		Faulty switch wiring	Check switch wiring	Check wiring for short between connector pins K and H (earth)
11	Displays pressure values too low and temperature values too high	Low Battery voltage	Recharge battery	The system does not give accurate readings when voltage is below 9.0V
12	Peak values not updated	Gate value set too high	Change Gate RPM in the display configuration menu	Peak values only updated while the engine RPM is greater than the Gate value
		Internal memory battery dead	Return unit to Stack for new battery service	Display shows !! Internal Battery Low !! warning on power up

No.	Symptom	Possible Cause	Remedy	Notes
13	Switch 1: Show peak values does not work	Switch 1 faulty	Replace switch	Disconnect switch and short its leads. If display changes, replace Switch 1. Otherwise check wiring.
		Faulty switch wiring	Check switch wiring for correct continuity	Pin K to red S1 wire less than 1.0 Ohm and Pin K to Pin H (earth) greater than 1M Ohms)
14	Switch 2: Show last alarm function does not work	Switch 2 faulty	Replace switch	Disconnect switch and short its leads. If display changes, replace Switch 2. Otherwise check wiring.
		Faulty switch wiring	Check switch wiring for correct continuity.	Pin L to red S2 wire less than 1.0 Ohm and Pin L to Pin H (earth) greater than 1M Ohms)

No.	Symptom	Possible Cause	Remedy	Notes
15	Switch 3: Change display layer function does not work	Switch 3 faulty	Replace switch	Disconnect switch and short its leads. If display changes, replace Switch 3. Otherwise check wiring.
		Faulty switch wiring	Check switch wiring for correct continuity.	Pin U to orange S3 wire less than 1.0 Ohm and Pin U to Pin H (earth) greater than 1M Ohms)
16	Switch 4 does not reset the trip value back to zero	Lap Marker Receiver triggered	Turn off Beacon	
		Switch 4 faulty	Replace switch	Disconnect the switch and short the leads together. If the display changes replace Switch 4. Otherwise check wiring.
		Faulty switch wiring	Check switch wiring for correct continuity.	Pin U to yellow S4 wire less than 1.0 Ohm and Pin U to Pin H (earth) greater than 1M Ohms)

No.	Symptom	Possible Cause	Remedy	Notes
17	External warning light dead when the display warning light is OK	Bulb has burnt out	Replace bulb	Swap with the other light to confirm burnt-out bulb. If not burnt out, check wiring.
		Faulty wiring to light	Check continuity of wiring.	Pin G to red AL wire less than 1.0 Ohm and Pin N to yellow AL wire less than 1.0 Ohm
		Driver circuitry burnt out	Return unit	
18	External gear shift light dead	Bulb has burnt out	Replace bulb	Swap with the other light to confirm burnt-out bulb. If not, check wiring
		Faulty wiring to light	Check continuity of wiring:	Pin G to red SL wire less than 1.0 Ohm and Pin M to green SL wire less than 1.0 Ohm
19	Display values and messages unclear or unreadable (poor contrast)	Display too hot or too cold	Ensure that the display is operated within the specified temperature range	Operating temperature is -20°C ($+5^{\circ}\text{F}$) to $+70^{\circ}\text{C}$ ($+158^{\circ}\text{F}$)
		ECU interface shorted (if fitted)	Check the two core screen ECU wires for short circuits	ECU wire is 300mm / 12" inside the main sensor leads sleeve. Make sure that none of the wire ends are shorted

No.	Symptom	Possible Cause	Remedy	Notes
20	No RPM speed reading	Incorrect wiring	Check the connection of the engine speed wire to the ignition system (or sensor, if used)	See instructions supplied in this manual. If connected directly to the coil, check that it is to the switched low tension side (usually the negative side).
21	Displayed RPM value too high or too low by a constant %-age amount.	System configured with wrong number of engine cylinders.	Reconfigure system to correct number of cylinders.	Ignition systems may either: -produce "waste" sparks giving double the number of cylinders per revolution
		Ignition system pulses per revolution not same as number of cylinders	Reconfigure system to correct number of pulses per revolution.	-use multiple coils where each additional coil gives proportionately fewer pulses per revolution.
22	Tachometer reading erratic, pointer jumps high or low	Incorrect wiring	Reconnect the tachometer as specified in this manual	
		Signal from ignition system or coil is noisy	Condition the ES signal by placing a resistor in line with the ES wire	Resistor values: 10K ohms for dedicated tach output; 47K Ohms for coil connection (Non-CDI); 100K Ohms for coil connection (CDI). Resistors 1/2W 5% 350v

No.	Symptom	Possible Cause	Remedy	Notes
23	Displayed speed value too high or too low by a constant %-age amount.	System configured with wrong number of targets per wheel revolution	Reconfigure the system with correct values	
		System configured with wrong circumference.		
24	No speed reading Speed reading erratic, value jumps high or low	Faulty sensor and/or wiring	Check sensor indicator for correct operation	Rotate the wheel by hand and check that the sensor indicator lights up as each target passes the sensor
		Incorrect sensor gap (too far or too close)	Check that the gap is approximately 1mm / 40thou	ST8131 (ST670) only
		Sensor and targets moving apart	Fabricate a more rigid sensor bracket	
		<ol style="list-style-type: none"> 1. Pulse amplifier not connected 2. Pulse amplifier out of adjustment 	Rotate wheels and check the LED on the ST492 for pulse signals	ST8130 (ST492) only
25	Speed reading dies after a short time	Ambient temperature too high	Shield the sensor from radiated heat from brakes and bearings. Insulate sensor from conducted heat with fibre washers. Duct cooling air around the sensor	Maximum temperature for correct operation of the wheel speed sensor is +80°C (175°F)

No.	Symptom	Possible Cause	Remedy	Notes
26	No alarms for water, oil, or fuel (temperatures and pressures) being displayed	All the alarms have been switched off	Switch on the required alarms	Alarms only operate when the engine is running above the RPM gate value.
		The engine RPM gate value is set too high	Reset the RPM gate to a lower value.	
27	Display and alarm light flash when the engine is running	Intermittent alarm caused by a parameter with its alarm level set too close to the normal operating value	Either change the value for the alarm or turn the alarm off	Press Switch 2 to see which sensor is causing the alarm
28	Fuel level reading does not change	<ol style="list-style-type: none"> 1. Fuel sender wiring not connected correctly 2. Faulty fuel sender 3. Fuel sender not suitable for use with ST8130 Display System 4. Fuel sender not calibrated 	<ol style="list-style-type: none"> 1. Check wiring 2. Check fuel sender 3. Check with your Stack dealer for suitable alternative <p>See Chapter 4 for information on how to calibrate the fuel sender.</p>	<p>If there is no reading from the fuel sender, remove the fuel sender unit from the tank, earth it to the vehicle with a clip lead, and move it by hand to verify that the voltage reading on the red lead changes. The voltage on the red lead should range from 0V to 5V.</p>

No.	Symptom	Possible Cause	Remedy	Notes
29	Lap time is not displayed automatically (Automatic receiver is fitted)	Lap marker receiver lead faulty	Check lap marker wiring	Press lap switch 4.
		Lap marker receiver faulty	Replace lap marker receiver	If display changes, replace receiver after checking its wiring.
30	The display unit functions correctly until the engine is started whereupon the digital display either freezes or flashes. The display functions correctly as soon as the engine is stopped.	High levels of electrical interference	Fit suppressors to the high tension leads. Use silicon resistive leads	

Appendix A. Template for the Display Module

Use the template on the following page for cutting out an aperture for the Display System.

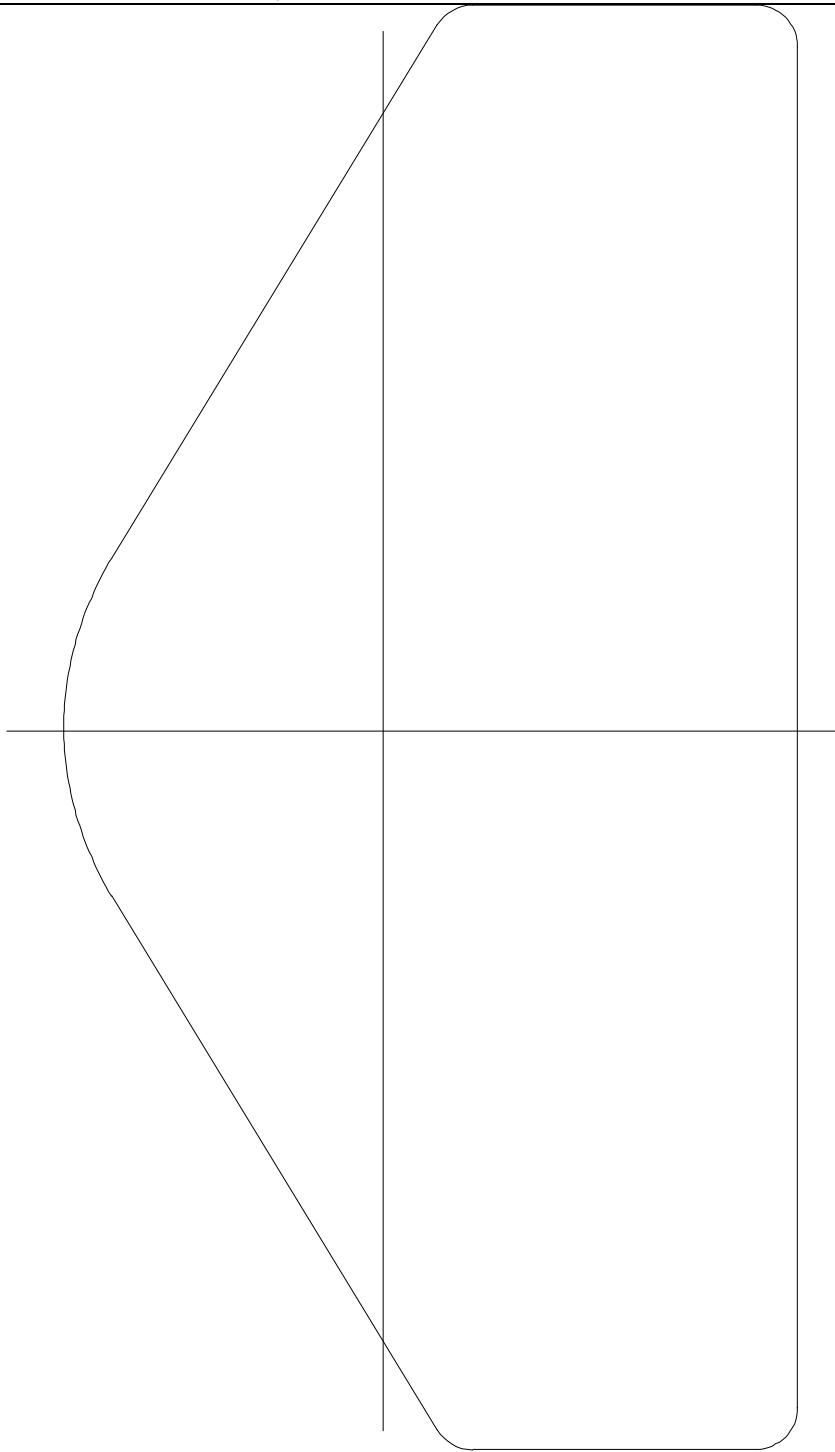

Reverse
of
template

Appendix B. Wiring Harness Diagram

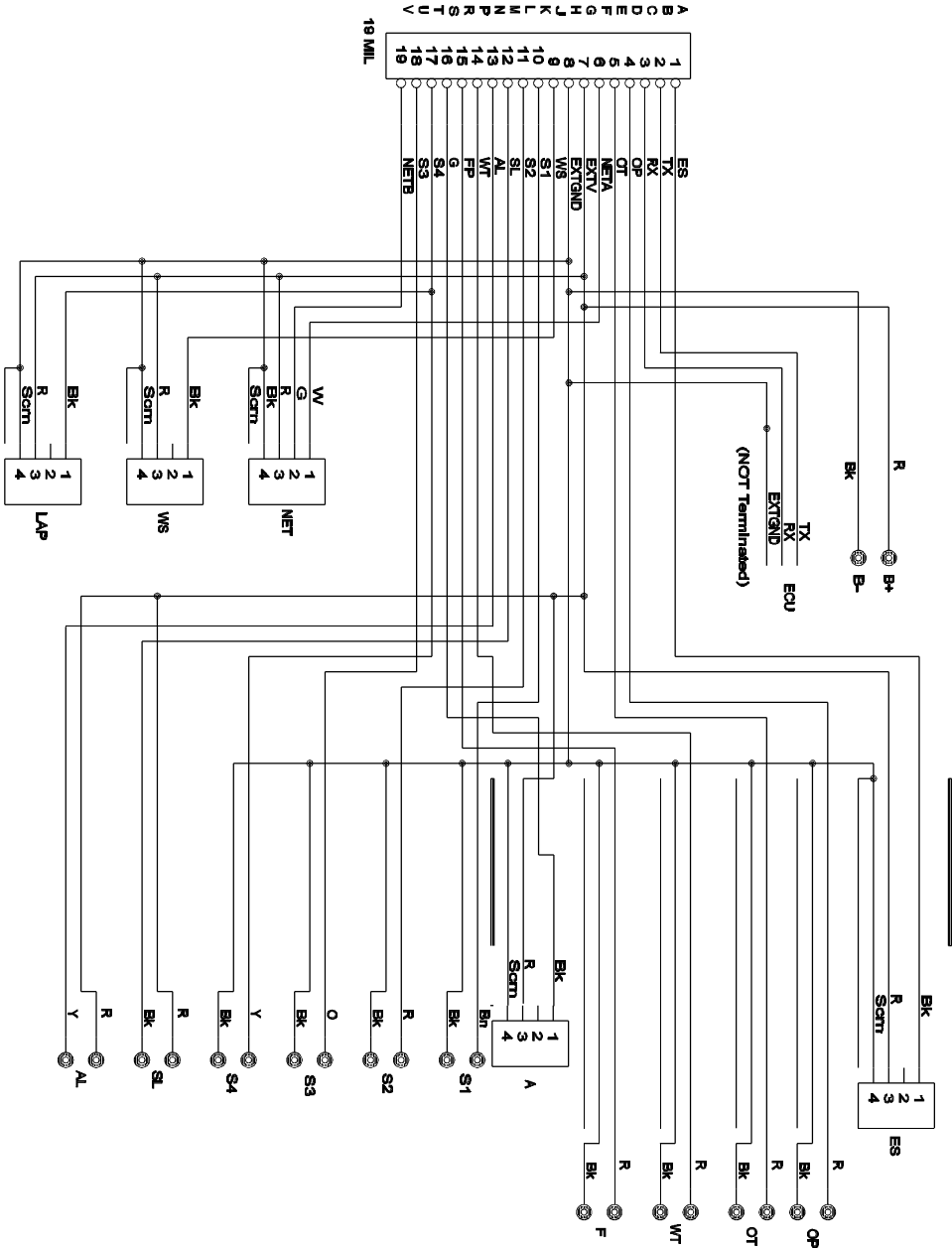

Appendix C. Summary of Switch Functions

Normal Operation

Switch or Switches	Functions
Switch 1	Show the peak values
Switch 2	Clear Alarm and Show Last Alarm
Switch 3	Clear Alarm and Change Display Layer
Switch 4	Reset the trip distance to zero and start the lap timer. The trip distance is reset after each lap.
Switches 1 & 2 together	Put system into configuration mode.
Switches 1 & 3 together	Change speed units to MPH or km/h (UK version only).
Switches 1 & 4 together	Reset the peak values and lap times.

System Configuration Mode

Switch or Switches	Functions
Switch 1	Decrease the alarm value of the parameter being displayed
Switch 2	Increase the alarm value of the parameter being displayed
Switches 1 & 2 together	Enable or disable an alarm for the parameter being displayed
Switch 3	Display the next configurable parameter
Switches 1 & 2 together	Enter Fuel Calibration mode (when applicable)
Switch 4	Exit configuration mode and return to normal operation mode

Fuel Calibration Mode

Switch or Switches	Functions
Switches 1 & 2 together	Enter Fuel Calibration mode
Switch 1	Decrease value
Switch 2	Increase value
Switch 3	Confirm value
Switch 4	Cancel and leave original calibration set

Returned Goods Form

In the unlikely event of a Stack part developing a fault and kindly requested to send the part back to Stack Ltd with a Form. Returning a part without this form will lengthen the repair cost of the repair.



requiring repairs, you are completed Returned Goods time and possibly increase the

Company _____	Customer _____
Address _____	(if different) _____
_____	Contact _____
_____	Tel No. _____
Contact _____	Fax No. _____
Tel No. _____	Return Date _____
Fax No. _____	

Details of part being returned

Part No. _____
Serial No. _____
Description _____
Other accessories included (Please include your fuel calibration table) (i.e. bracket, switches, etc.) _____

Details of Fault

Please complete as fully as possible. This will speed the repair and return of the parts.
Description of fault _____

Details of vehicle _____
Circumstances leading to fault _____

Stack Ltd use only

Engineer _____	Service No. _____	Date _____
----------------	-------------------	------------

Stack Ltd, Wedgwood Road, Bicester, Oxfordshire, OX6 7UL, England

Tech Support: 01869 240420 Sales: 01869 240404 Fax: 01869 245500

Index

- Air temperature
 - alarm, 19
 - display, 10
 - wiring label, 6
- Air temperature sensor
 - installation, 44
- Alarm warning light
 - external, 32
 - wiring label, 6
- Alarms, 13
 - air temperature, 19
 - battery voltage, 14, 19
 - clearing, 8, 15, 31
 - fuel level, 14
 - fuel warning, 19
 - oil pressure, 14, 19
 - oil temperature, 14
 - redisplaying, 15
 - showing last, 15
 - start-up, 7
 - switching on or off, 17
 - water temperature, 14, 19
- Amplifier. *See* Pulse amplifier
- Analogue tachometer, 5
- Battery voltage
 - alarm, 14
 - display, 10
- Battery voltage alarm, 19
- Beacon, 43
 - battery condition lamp, 44
 - power supply, 44
- Calibration
 - fuel level, 25
 - wheel speed (ST8130), 22
 - wheel speed (ST8131), 23
- Clearing an alarm, 15
- Configurable parameters, 19
- Configuring the display system, 17
 - switches to enter configuration mode, 31
- Contact breaker system connection, 34
- Custom configured ST8130, 29
- Datalogging subsystem
 - wiring label, 6
- Digital display panel, 5
- Dimensions, 30
- Display
 - backlighting, 8
- Display layers, 8
 - changing layer, 31
 - layer 1, 9
 - layer 2, 9
 - layer 3, 10
 - layer 4, 10
 - layer 5, 11
- Display module, 5
 - dimensions, 30
 - positioning, 30
 - template, 58
- Dual-Lock, 38
- Engine
 - cylinders, 19
 - ignition pickup, 33
- Engine speed (RPM), 32
- Engine speed (RPM), wiring label, 6
- External warning lights. *See* Warning lights
- Fastest lap time display, 11
- Fitting the display module, 30
- Fuel level
 - alarm, 14
 - calibration, 25
 - calibration Table, 28
 - display, 9
- Fuel level sensor
 - wiring label, 6
- Fuel Tank Sender calibration, 19
- Fuel tank sender Installation, 41
- Fuel warning light, 19
- Gate RPM, 19
- Gate value, 11, 12, 13
 - delay, 11

- Gear shift RPM, 19
- Gear shift warning light, 16
 - wiring label, 6
- High oil temperature alarm, 19
- High water temperature alarm, 19
- Ice warning. *See* Air temperature
- Ignition connection, 33
- Infra-red beacon. *See* Beacon
- Installing the Stack ST8130/ST8131, 29
- Internal Battery Low message, 13
- Labels on wiring, 6
- Lamps. *See* Warning lights
- Lap number
 - display, 11
- Lap time, 15
 - display, 11
 - fastest lap display, 11
 - recording manually, 11, 15
 - resetting, 16, 31
- Lap timing sensor
 - installation, 42
 - wiring label, 6
- Lights. *See* Warning lights
- MSS connector, 40
- Odometer
 - display, 9
- Oil pressure
 - alarm, 14, 19
 - display, 9, 10
- Oil pressure sensor
 - installation, 35
 - wiring label, 6
- Oil temperature
 - alarm, 14, 19
 - display, 9
- Oil temperature sensor
 - installation, 36
 - wiring label, 6
- Operating the system, 8
- Peak values, 11
 - displaying, 12, 31
 - memory, 13
 - resetting, 12, 31
- Performance parameters, 1
- Points connection, 34
- Power supply, 6, 7
- Pressure sensor. *See* Oil pressure sensor
- Pulse amplifier
 - adjustment, 40
 - connection, 40
 - installation, 38
 - specifications, 41
- Redisplaying last alarm, 15
- Resetting peak values, 12
- Resistor connection to coil, 34
- Returned goods form, 64
- RPM Gate Value. *See* Gate Value
- Shift light. *See* Gear shift warning light
- Shift RPM. *See* Gear shift RPM
- Showing the last alarm, 15
- Speed sensor (ST8130). *See* Pulse amplifier
- Speed sensor (ST8131). *See* Wheel speed sensor
- Speedometer, 7
 - change from MPH to km/h, 31
 - display, 9
- ST492. *See* Pulse amplifier
- ST765. *See* Air temperature sensor
- ST8130 components, 4
- ST8131 components, 4, 5
- Stack distributors worldwide, iv
- Switches
 - functions - normal operation, 31
 - installation, 31
 - operation - configuration, 18
 - summary of functions, 62
 - wiring labels, 6
- Switching the system on, 8
- Tachometer, 5
- Tell-tales. *See* Peak values
- Temperature sensors
 - installation, 36
- Temperatures
 - minimum displayable, 10
 - oil. *See* Oil temperature
 - water. *See* Water temperature

- Template for the Display Module, 58
- Tools needed, 29
- Trackside infra-red beacon. *See* Beacon
- Trip meter
 - display, 9
 - resetting, 31
- Troubleshooting, 47
- Units of measurement, ii, 8
- Unpacking, 4
- Velcro. *See* Dual-Lock
- Warning lights
 - additional, 32
 - alarms. *See* Alarm warning light
 - gear shift. *See* Gear shift warning light
 - installation, 32
 - maximum power, 32
- Water temperature
 - alarm, 14, 19
 - display, 10
- Water temperature sensor
 - installation, 36
 - wiring label, 6
- Wheel
 - circumference, 19, 22, 23
 - pulses per revolution, 19, 22, 23
- Wheel speed sensor
 - installation, 37
 - wiring label, 6
- Wiring harness, 6
 - extenders, 45
 - installation, 44
 - schematic diagram, 61
- Wiring labels, 6