



Stack Data Logging System Installation Guide

Part Number ST542061-002

Preface

Congratulations on choosing a Stack Data Logging System. To ensure that you enjoy years of reliable service please read this manual carefully.

Important Information

Stack data logging system are modular systems that utilise a hi-speed Can Bus network to transmit data around the system and to provide an ultra fast data retrieval.

Refer to the schematic system architecture diagrams provided in this manual to identify the correct connection of components for your system.

A key aspect of ensuring system reliability is the correct installation of harnessing. Please read and follow the advice given in this manual on installing harnessing before fitting the system to your vehicle.

The last section of this manual deals with the individual sensors. Before installation check which sensors your system is supplied with, and read the appropriate installation notes carefully.

Please Note: This manual does not cover Software or Dash System installation and operation. Please read the separate manuals supplied with your system which cover these aspects.

In case of difficulty please call

UK & Row Tel: + 44 (0)1869 240404 Fax: +44 (0)1869 245500
e-mail: sales@stackltd.com

USA Tel: 888 867 5183 Fax: 888 364 2609
e-mail: sales@stackinc.com

Contents	Page
Preface	1
Contents	2
ST8102 Fixed Channel Dash System Architecture	3
ST880x Configurable Dash-Logger System Architecture	4
ST890x Engineering System Architecture	5
ST895x Stand Alone System Architecture	6
Expanding the Systems	7
Important General Installation Guidelines	8
Connecting Power to the Systems	11
Fitting the Network Harness	12
Installing Data Acquisition Modules	12
External Shift and Warning Lights	12
Sensor Installation	13
Speed Sensor (ST670/ST671)	13
Pulse Amplifier (ST492)	15
Fluid Pressure Sensors (ST74x - Resistive Type)	17
Fluid Pressure Sensors (ST747 - Solid-state Type)	17
Fluid Temperature Sensors (ST76x - ST991)	18
Lap Timing System (ST546)	19
Lap Time Receiver (ST543)	19
Track side Beacon (ST544)	20
Accelerometer (ST791)	21
Rotary Position Sensors (ST77x/ST97x- Resistive Type)	22
Throttle Sensor (ST770/ST970)	23
Throttle/ Brake Sensor (ST779/ST979)	24
Steering Sensor (ST771/ST978)	25
Linear Displacement Sensors (ST97x)	26
Digital Interface Module (ST982/3/4)	27
Brake Pressure Sensor (ST749 - 0-5Volt Output)	27
Air/ Gas Temperature Measurement Sensors	28
K-Type Thermocouple Interfaces (ST464/ST66x)	28
Air Temperature Sensor (Thermistor Open Bulb - ST765/ST990)	29
Air/ Gas Mixture sensors (Lambda type ST693/993)	29
Air/ Gas Pressure Sensors (Solid State type - ST453/ST740)	30
Air/ Gas Differential Pressure Sensor (ST631)	31
Wiring Schematic Diagrams	32
ST872-905 ST880x Configurable Display Harness	32
ST873 ST810x Data Logger Module Harness	33
ST875 ST895x S/SR Stand Alone Sensor Harness	34
ST883 ST89xx E/ER Data Logger Module Harness	35
Troubleshooting, System and Data Download	36
Sensors	38
Index	40

ST8102 Fixed Dash logger System Architecture

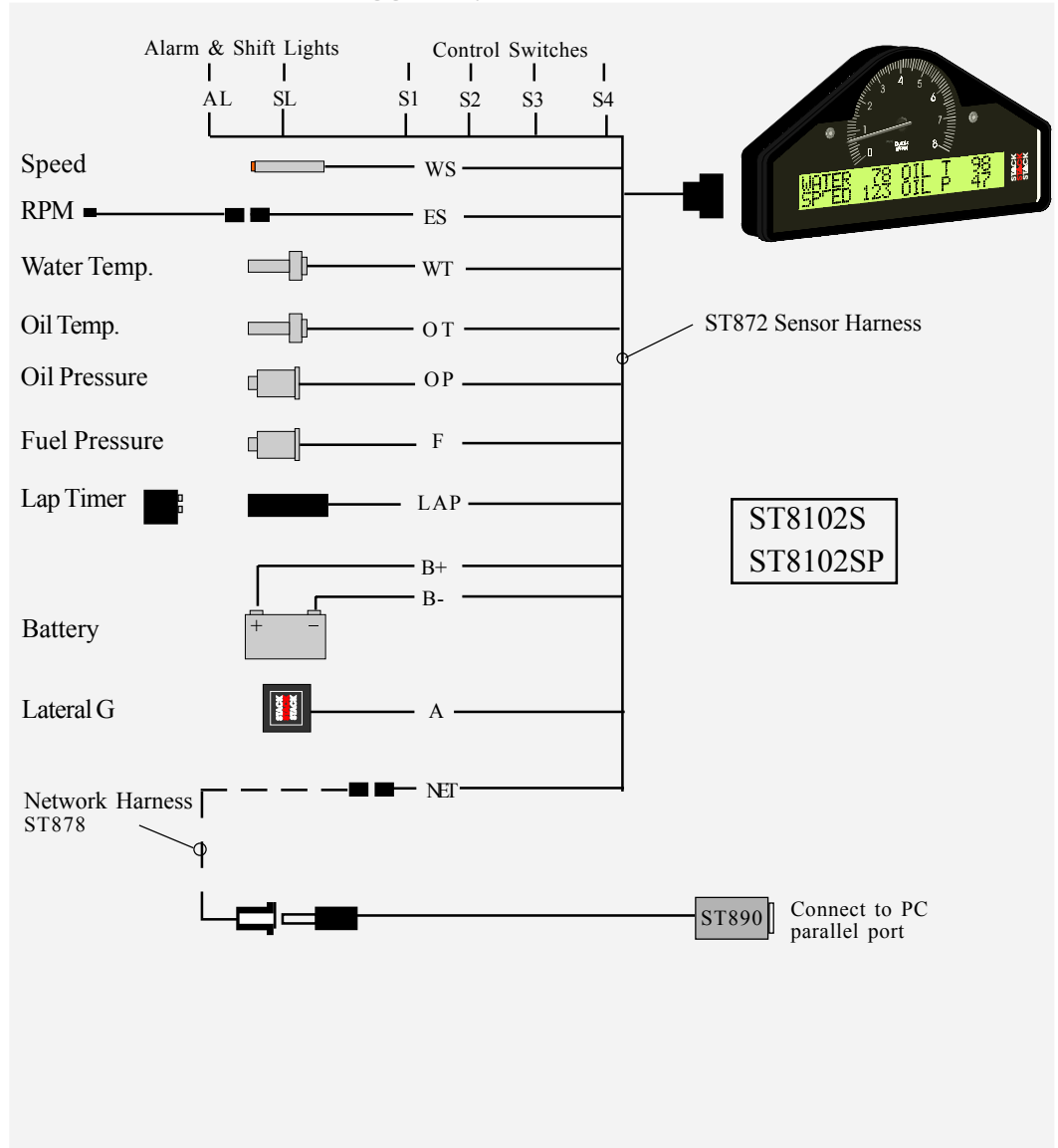

ST880x Configurable Dash Logger System Architecture

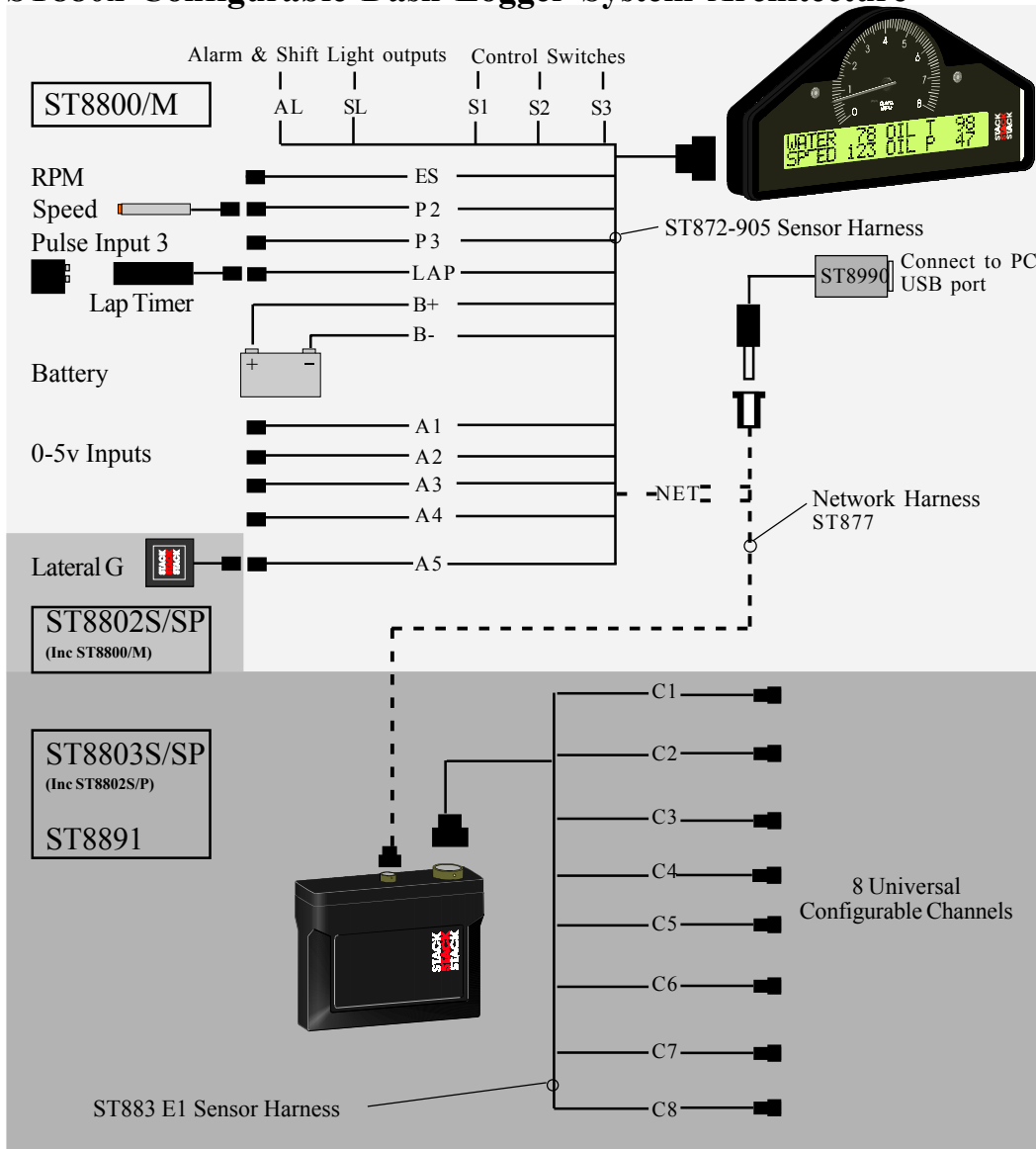

ST890x Engineering System Architecture

Steering Wheel Based System (ST8600) or Display Based System (ST8100/8900)

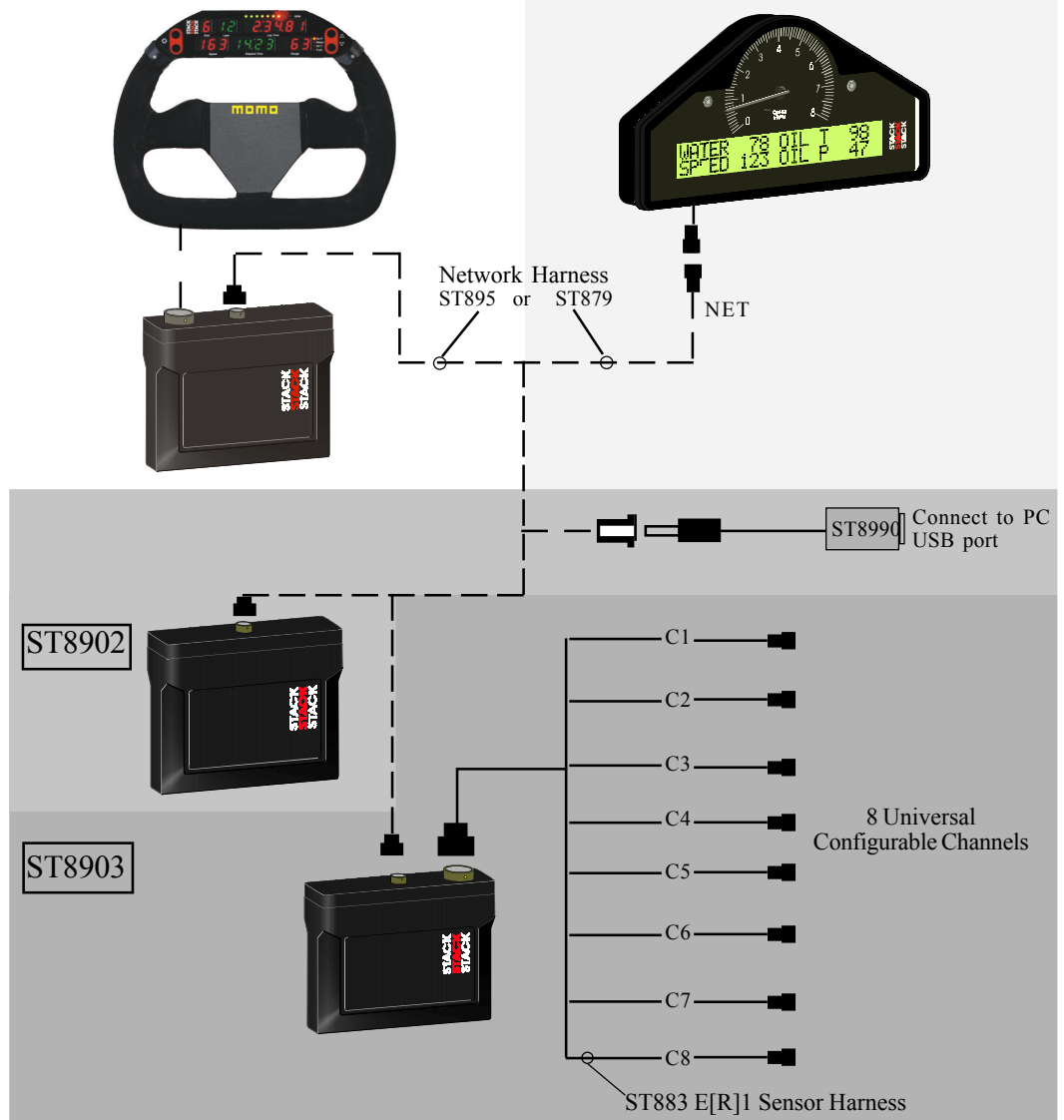

ST895x Stand Alone System Architecture

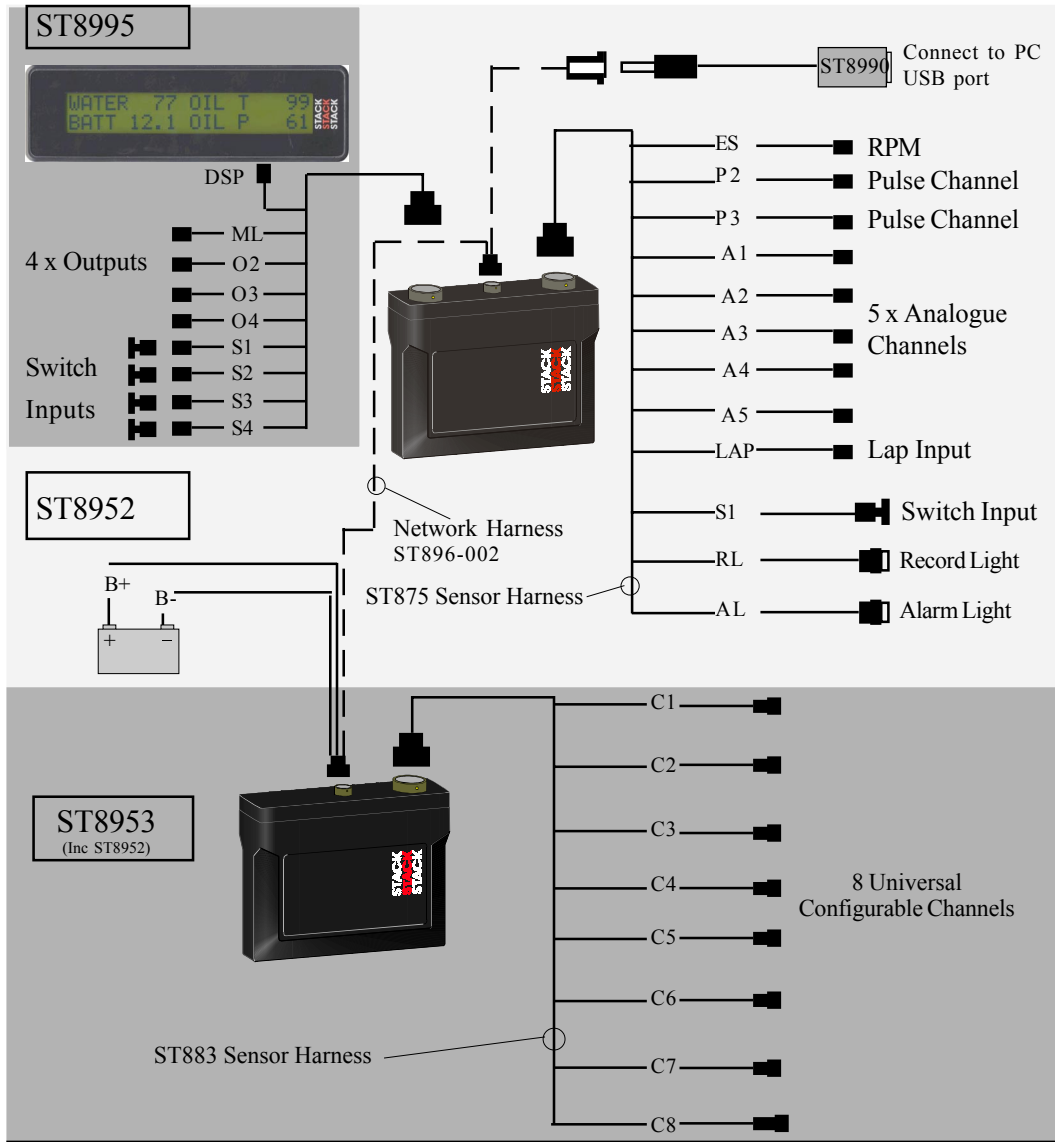

ST810x Fixed Dash Logger Systems:-

ST8102S = 8 Channel Driver Dash-Logger (ST867R)

ST8102SP = 8 Channel Driver "Plus" Dash-Logger (ST867R)

ST8800 Configurable Display Systems:-

ST8800 = 9 Channel Configurable Display System (ST869)

ST8800M = 9 Channel Configurable Display System "Max" (ST869)

ST8891 = 8 Channel Expansion module for ST8800/M (E1)

ST880x Configurable Dash Logger Systems:-

ST8802S = 9 Channel Configurable Dash-Logger (ST869R)

ST8802SP = 9 Channel Configurable Dash-Logger "Max" (ST869R)

ST8803S = 17 Channel Configurable Dash-Logger (ST869R + E1)

ST8803SP = 17 Channel Configurable Dash-Logger "Max" (ST869R + E1)

ST890x Configurable Engineering Systems:-

ST8902 = Recorder Module (ST823)

ST8903 = Input/Recorder Module (ST855)

ST8904 = Input Expansion Module (E1) and Recorder (ST823)

ST8905 = Input Expansion Module (E1) and Recorder (ST824)

ST8906 = Input Expansion Module (E1) and Recorder (ST825)

ST8907 = Input Expansion Modules (E1,E2) and Recorder (ST825)

ST8908 = Input Expansion Modules (E1,E2,E3) and Recorder (ST826)

ST8909 = Input Expansion Modules (E1,E2,E3,E4) and Recorder (ST826)

ST8910 = Input Expansion Modules (E1,E2,E3,E4,E5) and Recorder (ST827)

ST895x Stand Alone Engineering Systems:-

ST8952 = Display Sensor Recorder Module (DSR - ST819R)

ST8953 = Expansion Module (E1) and DSR Module (ST819R)

ST8954 = Expansion Module (E1), Display Sensor Module (DS-ST819) and R (ST823)

ST8955 = Expansion Module (E1), DS Module (ST819) and Recorder (ST824)

ST8956 = Expansion Module (E1), DS Module (ST819) and Recorder (ST825)

ST8957-0.5 = Expansion Modules (E1,E2) and DSR Module (ST819R)

ST8957 = Expansion Modules (E1-2) DS Module (ST819) & Recorder (ST825)

ST8958 = Expansion Modules (E1-3) DS Module (ST819) & Recorder (ST826)

ST8995 = Expansion Display (ST625) 4 x Switches (ST514) & Display Harness (ST891)

Where:

- E1,E2,E3,E4,E5 = Universal Input Expansion Modules (8 Inputs each)
- ST819 = Display & Sensor Module (3 pulse, 5 analogue Inputs - Configurable)
- ST819R = 512Kb Display Sensor Recorder Module (8 Inputs - Configurable)
- ST823 = 2MB Recorder Module (20 Channels, 50 Hz, 1000 Samples/Sec)
- ST824 = 4MB Recorder Module (20 Channels, 100 Hz, 2000 Samples/Sec)
- ST825 = 8MB Recorder Module (30 Channels, 200 Hz, 4000 Samples/Sec)
- ST826 = 8MB Recorder Module (45 Channels, 200 Hz, 4000 Samples/Sec)
- ST827 = 8MB Recorder Module (64 Channels, 200 Hz, 4000 Samples/Sec)
- ST855 = 512KB Input/Recorder Module (8 Inputs, 20 Chans., 50 Hz, 1000 Samples/Sec)
- ST867R= 512KB Input/Recorder Display Unit (Fixed Configuration)
- ST869= Display Unit (Configurable)
- ST869R=512KB Input/Recorder Display Unit (Configurable)

Important General Installation Guidelines

To ensure reliable service of your system please observe the following recommendations when installing your system

Recommended clearance from sources of interference

It is essential that Sensors, Harnesses and Modules are kept the recommended distance away from the following devices, and associated wiring.

Interference Source	Recommended Wiring Clearance
Ignition HT & coil leads	100mm (4")
Radio transmitters and aerial leads	75mm (3")
Fast switching inductive loads such as fuel injectors, hydraulic solenoids.	75mm (3")
Any powerful source of heat	Shield with reflective material

Mini sure-seal connectors

Mini Sure seal connectors offer excellent vibration and waterproof performance, however they do not have a positive locking mechanism and so must not be subject to bending or pulling loads, as such loads can cause the connector to fail.

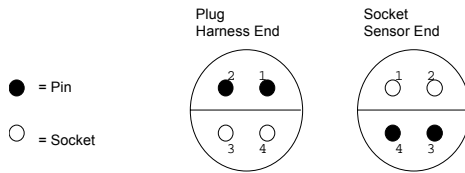

Pin	ST872-005	ST872-905	ST875 & ST883
1	Sensor Signal	Sensor Signal	Sensor Signal
2	Sensor Gnd	5 v supply *	5 v supply *
3	5/12 v supply	12 v supply	12 v supply
4	0 volt	0 volt	0 volt

* Mini Sure seal connectors are marked with red heatshrink to show a 5v supply on Pin 2.

Fitting wiring harnesses into the vehicle

Tie-wraps are recommended for fixing the harnesses into the vehicle.

However, it is important that the tie-wraps are not over tightened so as to cause damage to the wiring. (Tie-wraps should not leave a mark on the harness when they are removed).

Harnesses must **not** be routed over sharp edges and tight radius bends must be avoided (a minimum radius of 50 mm (2") is recommended). Harnesses should be carefully fed around the vehicle and not pulled through bulkheads or around chassis and vehicle components.

Repairing/ modifying sensor harnesses

The standard wiring harnesses supplied with the systems are designed to fit most vehicles with out requiring modification. Where the standard wiring harness is not long enough extender wires are available.

If necessary, wiring terminated with spade connectors can be modified by the user without requiring special tools.

Wiring terminated with mini-sure seal connectors should only modified by a skilled vehicle electrician with a proper mini sure-seal crimping tool.

Should a standard harness require extensive modification to fit into a vehicle it is recommended that a custom harness is made by a competent wiring technician.

If extensive repairs are required to a harness it is strongly recommended that the harness is replaced.

Repairing/ modifying network harnesses

The network harness transmits data at high speed between system modules and from the recorder module to the PC. It contains critical electronic components and is vital to the reliable operation of your system.

Therefore repairs or modifications to the network harness should only ever be attempted by Stack .

Extenders

Different length extender harnesses are supplied for connecting between the main sensor harness and additional sensors.

Routing advice is the same as for the Sensor Harness.

Using Dual-Lock fixing strips

Data Logging modules and some sensors are supplied with **Dual-Lock** adhesive backed fixing strips to provide a non evasive and reliable mounting method.

To use these strips first remove the backing paper from one strip, and attach it to a suitably located clean and flat surface on the vehicle, pushing the strip down firmly to ensure good adhesion.

Attach a second strip to the first strip making sure that it is aligned correctly and remove the backing paper. Attach the sensor/module to the second strip by pushing it firmly onto the strip.

Avoid separating the two strips for at least 24 hours after fixing.

To separate the Dual-lock strips insert a blunt bladed implement (such as a large flat blade screwdriver) between the sensor/ module and mounting surface and lever the strips apart. The sensor/ module can be simply reattached by pushing its strips back onto the strips stuck to the vehicle.

Connecting Power to the Main Sensor Harness

The ST810x and ST890x Data Acquisition system must be **only** connected to the 12V power supply and ground through the **Main Sensor Harness**. The ST895x Stand Alone systems are connected via the Network starter harness.

Ground the system directly to the battery negative terminal - Grounding to the chassis can result in a poor ground path, and cause a ground level variation between the Data Logging System and the Ignition System (which can prevent the data logging system from recording reliable data)

Important Note: Do not ground any other harness on the Data Logging System.

The Data Logging System should be connected to the 12 Volt power supply through the Ignition or Kill Switch (it is not recommended to switch the system on the ground side).

Fitting the Network Harness

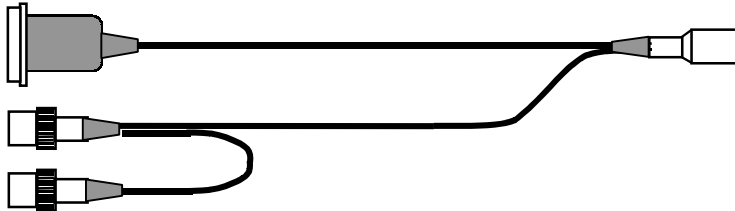

The download socket should be positioned so that it can easily be reached from outside of the vehicle.

To ensure reliable connection it is advised that the socket is lubricated with a non conducting grease and that the weather cap is fitted between downloads.

Important Reminder: The network harness carries high speed data and is vital to the reliable operation of your system. Take particular care to ensure network harnesses that have a sure-seal connector are fitted correctly into the main harness and are not subject to a bending load (see Important General Installation Guidelines).

Installing the Data Logging Modules

Although the modules are fully waterproof it is recommended that the connectors of the module are positioned to face away from direct water spray.

The modules should be mounted on a suitable bulkhead using the supplied dual lock fastening material - but must **not** be mounted on a large unsupported panel which may be subject to high vibration levels.

External Shift and Warning Lights

Only external shift and warning lights supplied by Stack are recommended for use with these system.

However, should you choose to fit your own external lights, it is important that the light draws a **maximum** of 2 watts. Connecting a higher wattage bulb will damage the external light driver circuit.

Sensor Installation Instructions

Note: Sensors that have a red sleeve at the 4-way mini sure seal connector require a 5 volt supply on **pin 2**, higher supply voltages will permanently damage the sensors. Compatible harnesses are also marked with red sleeves.

Speed Sensors (ST670/ST671)

These sensors, when used for measuring vehicle speed, are best fitted to an undriven outside¹ wheel. The sensors produce pulses which are then used to calculate the vehicle speed. The sensor is triggered by a number of 'Targets' (See Sensor Targets). It is essential to ensure that these devices are **NOT** mounted in a position close to any devices, or associated wiring, which are likely to interfere with the correct operation of the sensor.

Sensor Targets.

The targets can be any suitable metallic object which passes within range of the sensor tip. Iron or mild steel targets are preferred as they give a stronger signal to the sensor whilst aluminium, brass or copper targets give approximate one third of the sensing range (which makes setting up the sensor difficult and may cause the speed signal to be unreliable).

It is **IMPORTANT** that the sensor and targets should be rigidly mounted so they do not move with vibration. Targets should be at least 10 mm (5/8") diameter and stand 4 mm (5/32") proud (Fig.1). Smaller targets can be used but this will reduce the range. Small aluminium, brass or copper targets will generally NOT work.

Nothing other than the targets should come within 6 mm (1/4") of the end of the sensor. If the sensor mounting position is to be recessed, then a hollow of 24 mm (15/16") diameter and at least 4 mm (5/32") deep should be allowed around the sensor (Fig 2).

1) The outside wheel is on the left for clockwise, and on the right for anti-clockwise circuits.

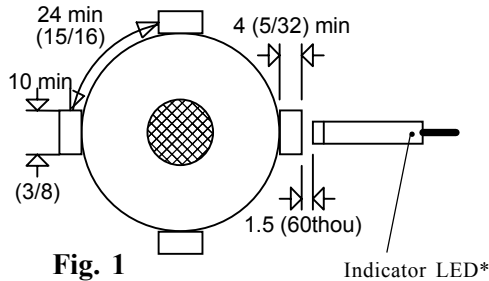

Fig. 1

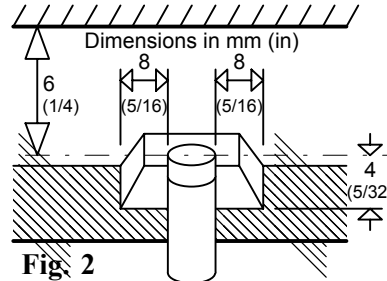

Fig. 2

ST670 Sensor Fitting and Adjustment.

1. Connect the sensor to the system and turn on the power.
2. Assemble the first (rear) nut onto the sensor.
3. Insert the sensor into the mounting bracket hole and fit the front nut.
4. Rotate the wheel and move the sensor slowly forward by undoing the rear nut counter-clockwise until the light comes on for every target.
5. Undo the rear nut half a turn more.
6. Without rotating the sensor or rear nut, finger-tighten the front nut.
7. Tighten the rear nut with a 13 mm AF spanner. Do NOT let the sensor rotate. Do not overtighten - one flat of the nut should be sufficient.

*The sensor has an in-built light (LED) which can be used to check that both the mechanical and electrical installations have been performed correctly. This light should be ON when a target is in front of the sensor.

ST671 Sensor Fitting and Adjustment.

1. Insert the sensor into the mounting bracket hole & align the target directly in front of the sensor
2. The gap between sensor & each target should be 1.25mm. This gap should not change by more than +/- 0.25mm for each target.

Checks for correct installation and adjustment

1. Rotate the wheel and check that the light comes on for each target and goes off between each target (ST670 only).
2. Check that both the sensor and targets are rigidly mounted.
3. Check that the front nut or any fixings do not cover any part of the sensing end.
4. **IMPORTANT** Check the gap between sensor and any of the targets is NOT less than specified so that there is no risk of the sensor hitting the targets
ST670 = 0.5 mm (20 thou.)
ST671 = 1.0 mm (40 thou.)

Pulse Amplifier Interface (ST492)

This interface is designed to convert the output of an existing transducer, which generates a pulsed signal whose characteristics are not compatible with Stack systems. This incompatibility may be due either to insufficient voltage or lack of output current drive capability. The interface, which will have negligible loading effect on the signal, includes the facility to adjust the sensitivity and it can therefore be used with a wide variety of transducers.

Mechanical Installation

On one side of the module there is a small red LED and a potentiometer access hole. This potentiometer is used to alter the sensitivity and the LED is used to give visual confirmation of correct adjustment. Access to this part should therefore be considered when choosing a mounting position.

Electrical Connection

The plug, the smaller of the two connectors, is the connection to the sensor. The input of the interface should be connected to the transducer output by a single wire (Pin 1) if it (the transducer) is already connected to the vehicle electrical system, for supply purposes or because it is already interfaced to other equipment.

If the transducer is only to be connected to the stack system then two wires must be used, as a signal common (PIN 4) is required.

Pin	Signal Description
1	Signal from sensor
2	No Connection
3	No Connection
4	0 volt

Sensor Adjustment

Once the system has been fully wired power should be applied.

At this stage it is desirable, if possible, to arrange for the transducer to generate a low frequency signal. If this can be arranged, the red LED at the end of the interface should be observed and should be seen to flash as each signal is received. If the frequency is higher than approximately 10 flashes/second the LED may only appear to dim, as the flashing is too fast for the human eye to see. If the above does not happen it will be necessary to adjust the input sensitivity of the interface to match the transducer. This is accomplished by turning the small screw head which can be found recessed in the hole adjacent to the LED. This should be adjusted whilst in operation until the LED flashes consistently.

Fluid Pressure Sensors (ST74x - Resistive Type)

These are the standard Stack resistive pressure sensors:

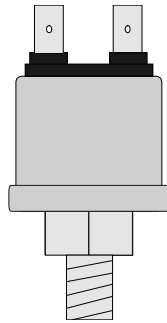

Sensor type	Max. Pressure	Thread Size
<i>0-10 Bar (150Psi) Pressure sensors</i>		
ST744*	10 bar / 150 psi	M10 x 1
ST745	10 bar / 150psi	1/8" NPTF
ST746+	10 bar / 150 psi	1/8" BSPT
<i>0-2 Bar (30Psi) Pressure sensors</i>		
ST741*	2 bar / 30 psi	M10 x 1
ST742	2 bar / 30 psi	1/8" NPTF

* 1/8" NPTF thread supplied with M10 x 1 adapter

+1/8" NPTF thread supplied with 1/8" BSPT adapter

Sensors that have a "K" after the number i.e. ST744K will be delivered with a 1.4Mtr sure seal to spade extender harness

Fluid Pressure Sensors (ST747 - Solid-State Type)

The 0-10 Bar (150psi) ST747 solid-state pressure sensor can be used for monitoring oil and fuel pressure. The sensor has a 1/8th BSP tapered thread. These are high accuracy sensors that can be used with ST89xx engineering systems. They are supplied with 300mm of cable and a ready wired mini sure seal connector for direct connection to the ST883/875 compatible range of sensor harnesses. **Note: The ST747 requires a 5 volt supply on Pin 2, see note on page 13.**

Installing Fluid Pressure Sensors

Do not screw these sensors directly into the engine block, as the high vibration levels produced by many racing engines will reduce the life of the sensor.

To remote mount these sensor use a suitable pressure hose to connect the sensor to the monitoring point. Do not overtighten the sensor.

Fluid Temperature Sensors (ST76x - Thermister Type)

These are the standard Stack resistive sensors:

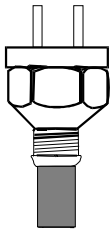

Sensor type	Temperature Range	Thread Size
ST760	150 °C/ 302°F	1/8" BSPT
ST761	150 °C/ 302°F	M14 x 1.5
ST762	150 °C/ 302°F	M10 x 1
ST764	150 °C/ 302°F	1/8" NPTF

Sensors that have a "K" after the number i.e. ST762K will be delivered with a 1.4Mtr sure seal to spade extender harness

These sensors can be used for monitoring any type of fluid temperature.

Fluid Temperature Sensor (ST991)

These are small high accuracy sensors that can be used with ST890x engineering systems. They are supplied with 300mm of cable and a ready wired mini sure seal connector for direct connection to the ST883 range of sensor harnesses.

Note: *The ST991 requires a 5 volt supply on Pin 2, see note on page 13.*

Sensor type	Temperature Range	Thread Size
ST991	150 °C/ 302°F	M6

Fitting the temperature sensors

Mount each temperature sensor directly in the appropriate fluid line. Screw the sensor into a suitable mounting boss, so that its tip is positioned in the middle of the flow of fluid.

Lap Timing System (ST546)

Overview

Stack Lap Timing system beacon transmit a dedicated coded signal which only Stack On-vehicle Lap Time Receivers will trigger off (the lap time receiver will not trigger of other manufacturers beacon).

However, as all standard Stack Lap Timing Systems use the same code, it is usually only necessary to put one beacon out at a circuit. However, if the height of the lap time receiver is significantly different between types of vehicle, an additional beacon may be required. To ensure reliable performance beacons must be kept 4 Metres apart - however beacons which are located more than 10 seconds track distance apart will cause false lap times to be recorded.

On-vehicle lap timing receiver (ST543)

The lap timing receiver is activated by the infra-red beam produced by the trackside beacon positioned at the side of the circuit.

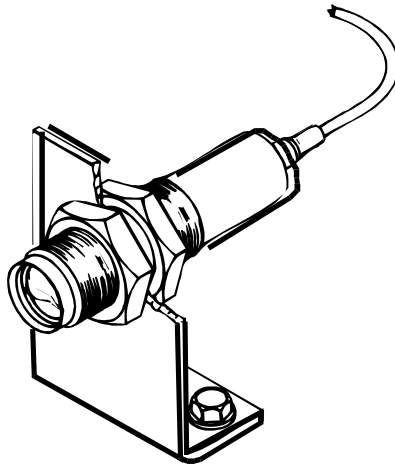

The receiver is supplied with two M18 x 1mm nuts so it can be clamped onto a rigid plate or bodywork panel.

The receiver must be positioned horizontal and square to the axis of the vehicle and should not be located behind perspex or glass.

Remove the red protective shipping cap before use.

The receiver has a protective lens cover which should be carefully cleaned at regular intervals. Care must be taken not to scratch this cover when cleaning the vehicle.

Trackside infra-red lap beacon (ST544)

To ensure that reliable lap times are recorded it is important that the track side beacon is set up to meet the following criteria.

The beacon is at the same vertical height as the on-vehicle receiver.

The beacon is level so that it emits a horizontal beam (it is important that the on-car receiver is also level).

The beacon is positioned so that the vehicle is consistently driven in a straight line when it passes the beacon and that the vehicle will pass between 2 and 30 metres (6 to 95ft) of the beacon.

The beacon is mounted so the transmitting diodes are in the vertical plain.

The beacon is positioned 4 metres (12 feet) from any other beacon.

The beacon is positioned so that it does not point directly into, or away from, the sun. (A low bright sun can be a particular problem in the morning).

If the unit is used for lengthy periods in very hot, sunny conditions, it should be protected by shading it from direct sunlight.

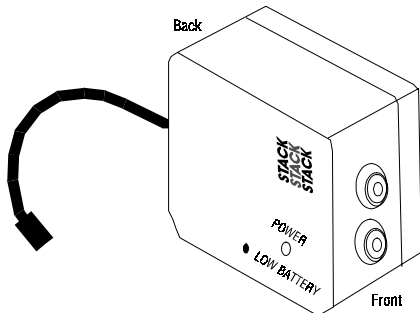

Power supply requirements

The beacon operates from a 12v DC supply.

A sealed lead-acid battery with a minimum rating of 2.5 Amp/hour is recommended (this provides about 15 hours of continuous operation).

The condition of the battery is indicated by the colour of the LED indicator on the front panel of the unit:

1. Green: OK
2. Red: Low Voltage (replace the battery).
3. No Colour: Battery dead or disconnected

Accelerometer (ST791)

This sensor should be mounted on a low vibration surface (i.e. a surface with no obvious resonance). It is best to mount the sensor near to supporting ribs at the edge of body panels as opposed to the (unsupported) centre of the panel.

Sensor orientation

Force Required	Sensor Orientation	Positive G value	Negative G value
Lateral G Longitudinal G	As per label LEFT= Front	Left turn Acceleration	Right Turn Braking

Note: The STACK label indicates the direction of the G force to be measured. An alignment error of 8 degrees will cause an approximate 10% error in the indicated G reading.

Sensor attachment

The sensor should be fitted to a suitable flat surface. Recommended methods of attachment are, Double sided Adhesive strip or Adhesive foam strip.

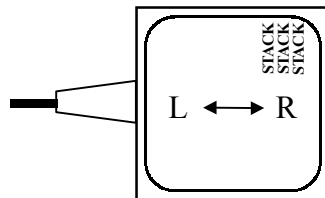

IMPORTANT

Mount the sensor with the Left side facing the Left side of the vehicle (as viewed from the driving seat) to measure lateral G forces.

Note: Fabric velcro is a suitable fixing material but Dual-Lock is **NOT** recommended.

Sensor position

The G sensor should be positioned as near as possible to the vehicles centre of gravity (C of G). Positions near to the front or rear of the vehicle will measure the relative motion of each end rather than the vehicle as a whole.

In addition the sensor should not be fixed to a structure which may transmit high frequency vibration - e.g. such as a transmission tunnel

Operational check

It is possible to use the earth's gravity (1.00 G) to check the correct operation and calibration of a G Sensor. Laying the sensor on a flat surface, so that the left side is on the top will produce a reading of 1.00 G +/- 0.1 G.

Turning the sensor over (Right side on top) will give a reading of -1.00 G +/- 0.1 G.

Rotary Position Sensors (ST77x - Resistive Type)

Stack supply three types and two versions of rotary throttle position sensor.

ST810x Range	ST89xx Range	Sensor Type Description
ST770	ST970	Throttle Position Sensor
ST779	ST979	Throttle/ Brake Position Sensor
ST771	ST978	Steering Position Sensor

ST770/ST970 Rotary throttle position sensor



This is the standard throttle position sensor supplied with Stack Data Logging systems.

This sensor is designed to be fitted onto the end of throttle butterfly shaft. Universal mounting holes are provided to allow the sensor to be bolted onto most standard throttle bodies.

The ST970 version for engineering systems requires a 5 volt supply on Pin 2, see note on page 13.

Important Note: This sensor is not designed to take radial loads and must be carefully aligned with the centre line of the throttle shaft - otherwise misalignment will shorten the life of the sensor.

ST779/ST979 Rotary throttle/brake position sensor

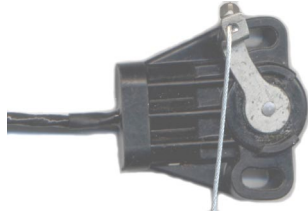

This sensor is a sprung loaded lever operated sensor.

The lever should be attached by the supplied locking wire to a throttle or brake pedal rocker

1. Mount the sensor such that it does not interfere with the drivers feet or operation of the controls.
2. Once the intended location for fixing is determined drill 4.5 mm (3/16") holes to provide clearance for the supplied bolts.
3. Bolt the sensor in place and connect to Sensor Harness
4. Using the length of cable supplied, pass the end of the cable through the hole in the lever arm and attach the other end to the side of the pedal.
5. Adjust the cable tension until the lever arm is just pulled away from it's rest position. This adjustment needs to be checked regularly to remove any slack in the cable which may give rise to errors in throttle/ brake position.

The ST979 version for engineering systems requires a 5 volt supply on Pin 2, see note on page 13.

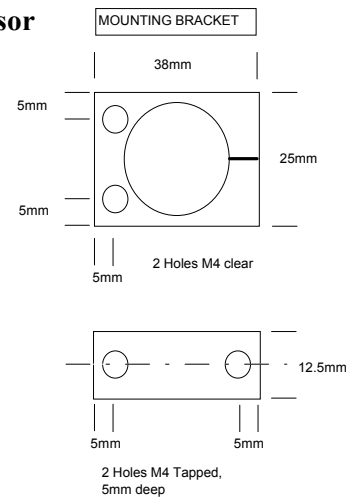
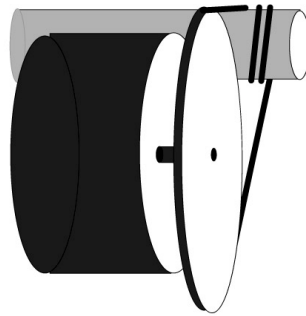
ST771/ST978 Rotary steering position sensor

Bolt the sensor mounting bracket to a part of the vehicle adjacent to the steering column ensuring the sensor and column are parallel.

The nuts and bolts supplied can be used to clamp the mounting bracket onto a suitable surface, or the bolts can be threaded directly into the side of the bracket. The small 'O' ring supplied with the sensor can be used as a 'Tyre' on the pulley, or the large 'O' ring can be looped over a clean section of the column & the sensor pulley (as indicated in the above diagram).

Failure to align the sensor accurately will cause the 'O' ring to creep & the resulting reading to drift.

Should the 'O' ring slips on the steering column the 'O' ring can be looped two times around the column to give it more grip. If slippage still occurs rub an abrasive cloth over the contact area on the shaft to increase friction, alternatively glue a high friction material to the shaft to increase grip.

The 'O' ring should be under sufficient tension to prevent slippage, but be aware excessive tension will cause the sensor to fail prematurely.

The ST978 version for engineering systems requires a 5 volt supply on Pin 2, see note on page 13.

Linear Displacement Sensors (Resistive)

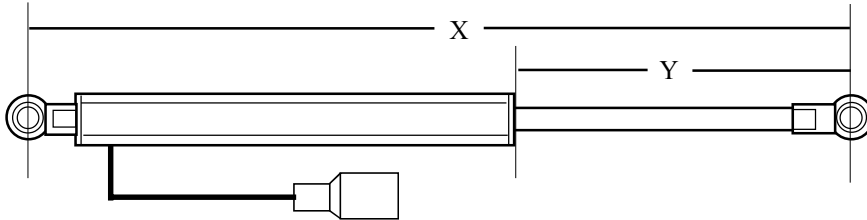

Sensor	X max	X min	Y max
ST972	250mm (9.8")	200mm (7.9")	50mm (1.9")
ST973	350mm (13.8")	250mm (9.8")	100mm (3.9")
ST974	550mm (21.6")	350mm (13.8")	200mm (7.9")

Measurement of suspension movement

To measure high frequency signals such as suspension movement the linear displacement sensor **must** be connected to the data logging module through an ST983 digital interface (see following page).

For maximum accuracy the sensor should be positioned parallel to the damper unit.

Measurement of steering position

The linear displacement sensor can be connect directly into the harness as direct replacement for a rotary steering position sensor.

General installation notes

The range of movement between the maximum compression and extension **must not be exceeded** otherwise the sensor will be damaged.

The sensor must be fixed to the vehicle through the spherical bearing mountings provided. Failure to do this will result in bending forces being applied which will cause the premature failure of the sensor..

Differential Voltage Interface with DSP (ST98x)

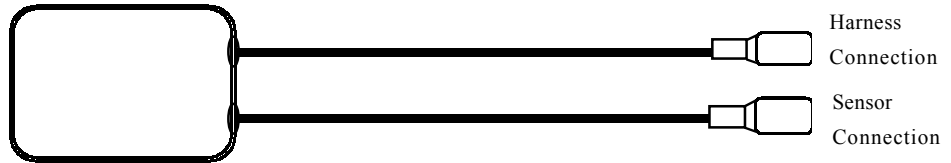

Sensor	Range	Over Range	Resolution
ST982	+/- 1 volt	-0.5 to +2 volts	1 mV
ST983	+/- 5 volt	-2.5 to +10 volts	5mV
ST984	+/- 20 volt	-10 to +40 volts	20mV

The ST983 digital interface module is supplied with all Stack suspension movement sensors. This module must be fitted between the linear displacement sensor (ST972/3/4) and the harness for suspension measurement applications. The interface module must be mounted within 200 mm of the sensor connection with the supplied **Dual-Lock** adhesive strips.

Brake Pressure Sensor (ST749 - 0-5 Volt Output)

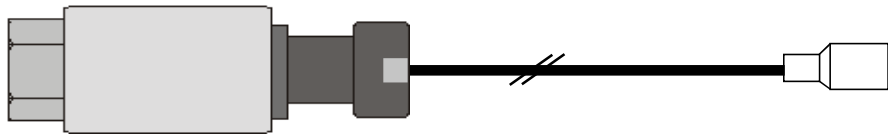

The ST749 Brake Pressure sensor is recommended for brake systems not exceeding 100 bar (1500 psi). The burst pressure of this sensor is 4500 psi. The sensor is supplied with a Dash 3 to 3/8" UNF male/male adaptor which should be connected using a suitable adaptor and 3 way connector block inserted into the brake line.

Important Note: Reliable braking performance is vital to the safe operation of your car and only a competent mechanic should attempt to fit this sensor - and only high pressure brake line quality fittings should be used.

The ST749 requires a 5 volt supply on Pin 2, see note on page 13.

Air/Gas Temperature Measurement Sensors

To measure air or gas temperature between -50°C to 800°C Stack provide digital thermocouple interfaces.

To measure air temperature between -20°C to 60°C. Stack provide an open bulb thermister sensor

K-type thermocouple interfaces (ST464/ST663/4)

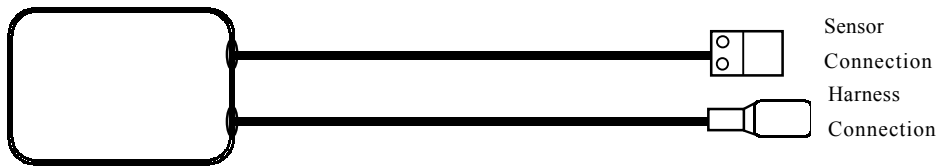

Interface	Temp. min	Temp. max	Resolution	Compatible Modules
ST464	200°C (392°F)	800°C (1470°F)	0.2°C	S/SR/IDU
ST663	-50°C (-58°F)	200°C (392°F)	1.0°C	E/ER/H/HR
ST664	200°C (392°F)	800°C (1470°F)	1.0°C	E/ER/H/HR

These interfaces can be connected directly to any k-type thermocouple probe. Standard Stack probes include the ST766 straight thermocouple probe or ST767 Rubbing Brake Thermocouple probe. The sensors are supplied with **Dual-Lock** adhesive strips for fixing.

Air Temperature Sensor (Thermister Open Bulb Type - ST765/ST990)

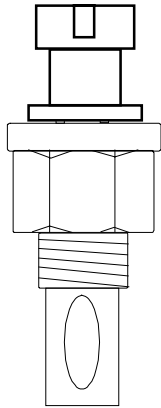

This sensor is fitted with an M10 x 1.25 male thread and will measure temperatures between -20°C and 60°C (-4°F to 140°F).

To Measure Engine Inlet Air Temperature

Mount the sensor directly into the plenum, ensuring the tip is placed well into the air flow.

To Measure Ambient Air Temperature

Mount the sensor away from direct air flow and as far away from sources of heat as is possible.

A good location is to locate the sensor behind the front bumper.

The ST990 version for engineering systems requires a 5 volt supply on Pin 2, see note on page 13.

Lambda Sensor ST993 (Or ST693 including digital interface)

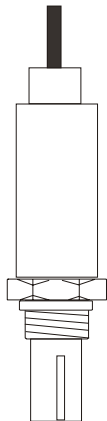

This sensor is fitted with a 4-way mini sure seal connector and two male spades. The M18 x 1.5 male thread has a tightening torque of 40-52Nm.

The sensor gives a 0 - 1 volt output and requires an ST982 digital interface for interfacing the output signal into ST890x universal configurable channels.

The two male spades need to be connected to the 12 volt power supply through the Ignition or Kill switch for pre-heating the sensor.

Air/ Gas Pressure Sensors (Solid State Type - ST453/ST740)

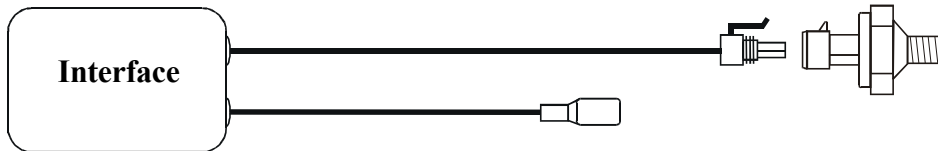

Please note that this sensor is an absolute pressure sensor and will measure over the following pressure range.

0.4 to 3.8 bar (5.5 to 55 psi) Absolute Pressure

-0.6 to 2.8 bar (-9 to 40 psi) relative to normal sea level atmospheric pressure

This absolute pressure sensor is supplied as two types:

ST740 which consists of the sensor element and a 2Mtr extender. The sensor requires a 5 volt supply (see note on page 13), and has a 0-5volt output.

ST453 which has two elements a sensor and a digital interface module. The digital interface module must be connected between the Sensor Harness and the Sensor - it is not possible to connect the sensor directly to the harness. The digital interface module should be fixed to a suitable surface using the supplied **Dual-Lock** fixing material.

It is recommended that the sensor is connected to the plenum indirectly using a flexible hose connection. The sensor has an 1/8" NPTF thread.

The hose from the sensor to the plenum should be of a suitable vacuum-proof with no tight-radius bends liable to kink and block the line and secured clear of any linkages or other moving parts.

The plenum connection point must not be fitted to a venturi within, or leading into, the plenum as this will give a false reading.

Differential pressure Sensor (ST631)

Pressure Ports

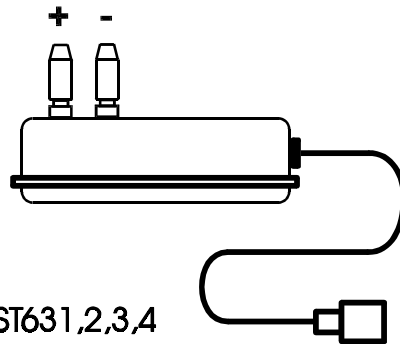

Connections to the Sensor

The Differential Pressure Sensor has two input ports designated + (pos) and - (neg). The output frequency of the sensor is proportional to the pressure difference between these two ports. In normal use the reference pressure or the lower pressure would be applied to the - (neg) port and the active pressure or higher pressure to the + (pos) port.

The pressure connections to the sensor are made via two 5mm diameter barbed pressure ports. These ports are intended to be used with Rubber, Nylon, and PVC tubing. It is recommended that the tubing is secured to the pressure port with a small tie-wrap or clamp. When the sensors are used in a high vibration environment the length of unsupported tubing should be kept to a minimum.

For low pressure operation, 2 Bar or less, thin wall tubing should be used to minimise the package stress and reduce the possibility of snapping the pressure ports. For pressures greater than 2 Bar thicker tubing (0.9mm wall thickness) or reinforced tubing is required. The differential sensor is most susceptible to package stress at the pressure ports, as the two tubes can easily be pushed together or pulled apart. If rigid tubing is used, spacers should be used to keep the tubes parallel and aligned with the pressure ports for a short distance.

This type of sensor is suitable for use with non-corrosive, non-ionic working fluids such as air, dry gases and the like. It is therefore important to ensure that the sensor is mounted so that fluids which will cause damage to the sensor (e.g. water, fuel, etc.) are prohibited from entry to it. **This is most easily accomplished by mounting the sensor in a location above the sampling position.**

Wiring Schematic Diagrams ST872-905 Configurable Dash Sensor Harness

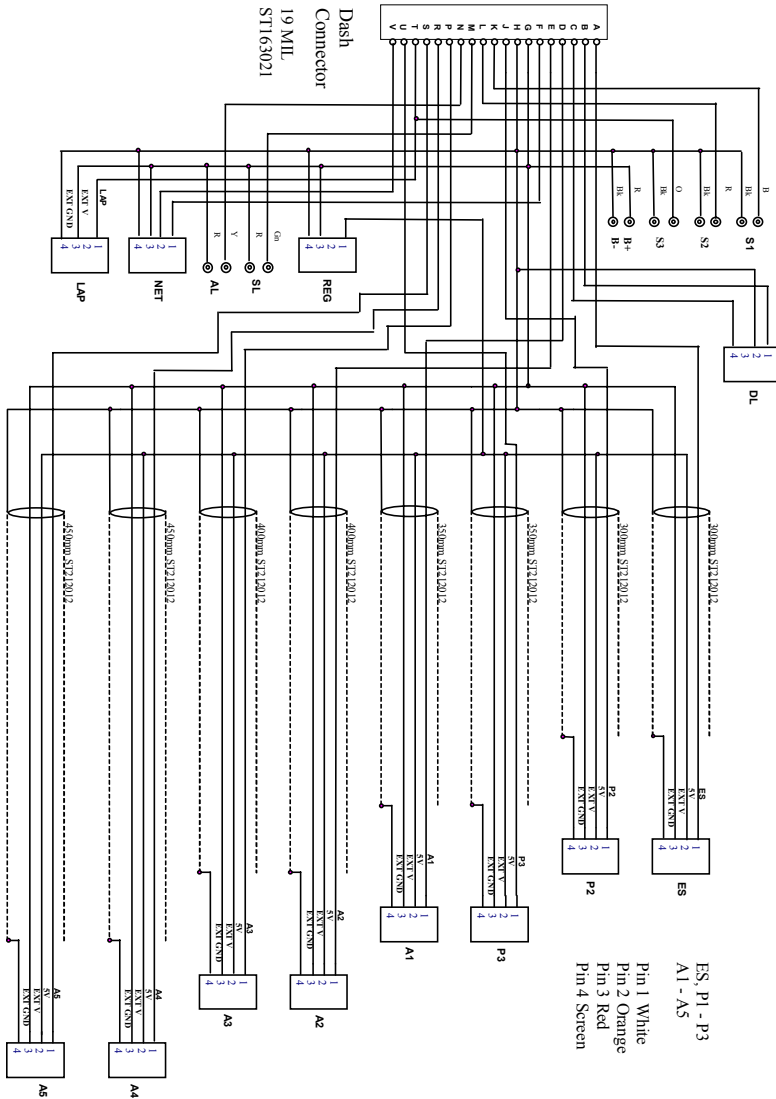

ST873 Sensor Harness (For ST810x HR Modules)

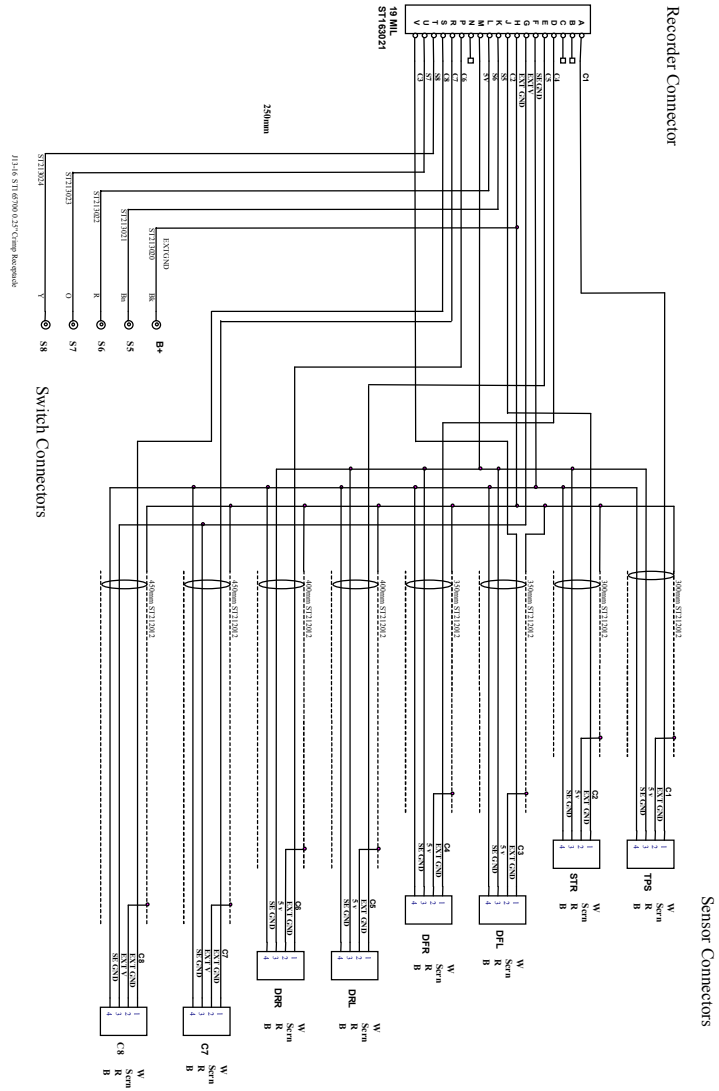

ST875 Sensor harness (For ST895x S/SR Modules)

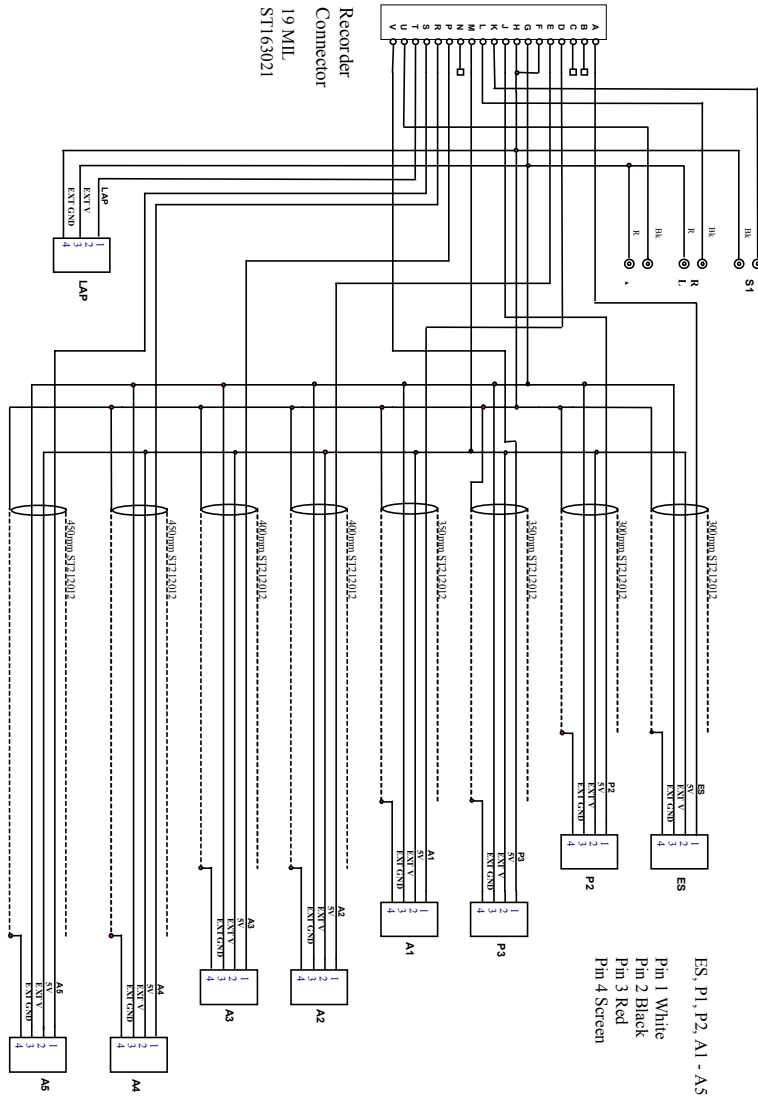

ST883 Sensor harness (For ST890x E/ER Modules)

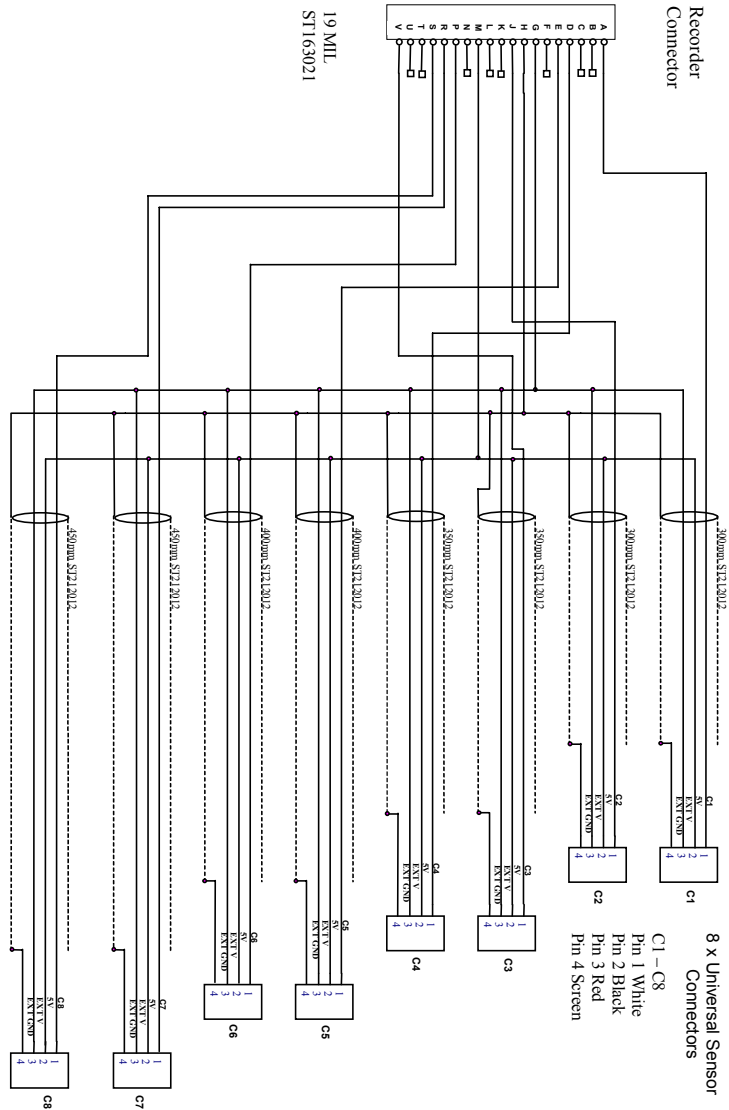

Troubleshooting System and Data Download

No.	Symptom	Possible Cause	Remedy
1.	System will not power up	Ignition is Off Battery is dead Power connection is faulty	Turn ignition on Charge/ replace Battery Check connections and harness
2.	Can not download data from recorder	System is not powered up Software has not been authorized for the recorder Network has not been configured Faulty connection on network harness Damaged network harness Incorrect parallel port configuration PC Download adapter is faulty/ damaged Computer has incorrect Power Saving Settings	Switch on power to the system Check software has been authorized for the recorder Run configure network routine from software Check all connections Replace harness Refer to Software Manual for setting Parallel Port Replace PC Download adapter Refer to Software manual for setting Power Saving
3.	No data recorded	Start-Logging conditions have not been met Network harness is not connected correctly Network harness is damaged Recorder battery backup has failed Recorder program has been corrupted	Change start logging conditions - e.g. reduce Start-Log RPM value Check network harness connections Replace harness Call Stack for help Call Stack for help

No.	Symptom	Possible Cause	Remedy
4.	Recorded values are “frozen” at a constant value	<p>Network harness has a loose connection</p> <p>Network harness has a fault</p> <p>Logger module has a fault</p>	<p>Check Network harness connections</p> <p>Replace harness</p> <p>Call Stack for Help</p>
5.	Recorded data has Spikes on data traces	<p>System is picking up electrical interference from other vehicle electrical systems</p> <p>Interference is being transmitted on 12 V supply line</p>	<p>Route wiring away from sources of HT or radio transmitter antenna leads</p> <p>Move sensors and modules away from sources of HT</p> <p>Rectify problem with 12 V supply or fit filter between system and 12 V supply</p>
6.	System records multiple runs	<p>System is recording warm up data</p> <p>Bad 12 V or ground connection</p> <p>The Master Switch has a fault</p> <p>System is picking up electrical interference.</p> <p>Interference is being transmitted on 12 V supply line</p>	<p>Change start logging RPM i.e. Start-Log RPM value is set too low</p> <p>Check connections</p> <p>Move system ground to battery negative</p> <p>Replace Master Switch</p> <p>Route wiring away from sources of HT or radio transmitter antenna leads</p> <p>Rectify problem with 12 V supply or fit filter between system and 12 V supply</p>

Sensors

No.	Symptom	Possible Cause	Remedy
1.	Spikes on RPM trace or erratic RPM trace	System is not grounded correctly Ignition signal needs conditioning	Move ground to battery negative Refer to dash system manual
2.	Displayed RPM value too high or too low by a constant %	System configured with wrong number of engine cylinders	Configure cylinders
3.	Spikes or drop outs on speed trace	Sensor gap is too large Mounting bracket is moving or flexing Excessive movement on wheel bearing Sensor is failing due to excessive temperature	Adjust sensor gap Ensure mounting bracket is rigid Adjust bearing play Replace sensor
4.	Displayed Speed value too high or too low by a constant %	System configured with wrong number of targets	Configure correct number of targets
5.	Water or Oil Temperature sensor shows a fixed value of 999 or 99 psi	Temperature sensor has failed Faulty connectors	Disconnect Sensor if systems shows shows "0" replace sensor Check continuity of leads for short
6.	Water or Oil Temperature sensor shows a fixed value of 0° C or 0° F when engine temperature is above 12° C or 55° F	Temperature sensor has failed Faulty sensor connections	Disconnect sensor and short connectors together. If reading changes replace changes replace the sensor Check continuity of sensor leads for open circuits.

No.	Symptom	Possible Cause	Remedy
7.	Oil or Fuel Pressure sensor shows a reading of 999 PSI or 99.9 Bar	Pressure sensor has failed Faulty sensor connections	Replace sensor. Check continuity of leads for shorts
8.	Oil or Fuel Pressure sensor shows a reading of -9.9 or -99 psi	Faulty sensor Faulty sensor connections	Disconnect sensor. If reading changes to 999 replace sensor Check continuity of sensor leads for open circuit.
9.	Oil or Fuel Pressure sensor shows 0 PSI or low/slow reading	Pressure sensor has failed	Replace sensor
10.	Displayed Lateral-G reading floats	Sensor is not connected	Check connections, reconnect sensor
11.	Displayed Lateral-G reading shows constant -6.0 G	Sensor is damaged	Replace sensor
12.	Displayed Lateral-G reading shows constant 1.0 or -1.0 G	Sensor is installed incorrectly and is measuring vertical G	Reposition G sensor to measure Lateral-G
13.	Lateral-G and Speed traces look good but correct track maps can not be created	Sensor is fitted the opposite way round and is recording the incorrect signed G value	Rotate Sensor 180°
14.	Lateral G trace is zero through corners but shows up to 1.5 G or -1.5 G during braking	Sensor is installed incorrectly and is recording Longitudinal-G	Reposition sensor to measure Lateral-G
15.	Over a run steering trace drifts away from zero when steering is pointing straight ahead.	Insufficient grip between "O" ring and steering column.	Increase tension on the "O"ring Increase friction surface on the steering column Replace Rotary Steering sensor with a linear sensor

Index

Accelerometer (ST791)	21	Rotary Position Sensors (ST770 /1 /9)	23
Air/ Gas Lamda Sensor (ST993)	29	Rotary Position Sensors (ST970 /8 /9)	23
Air/ Gas Pressure Sensor (ST453/ST740)	30	Pulse Amplifier	15
Air/ Gas Differential Pressure Sensor (ST631)	31	Pressure Sensors	
Air/ Gas Temperature Sensors	28	Air/ Gas (ST453/ST740)	30
Air Temperature Sensor (ST765/ST990)	29	Boost (ST453/ST740)	30
Brake Pressure Sensor (ST749)	27	Oil (ST744/5/6/7)	17
Boost Pressure Sensor (ST453/ST740)	30	Fuel (ST741/2/4/5/6/7)	17
Damper Movement Sensors	26	Shift Light - External	12
Dash System Architecture	3	Speed sensor (ST670/671)	13
Data Logging Modules - installation	12	Stand Alone System Architecture	6
Digital Interface Module (ST982/3/4)	27	Steering Sensor (ST771/ST978)	25
Extenders (ST918020/21/22)	10	System Architecture	3
Fluid Pressure Sensors (ST741/2/4/5/6/7)	17	Dash based Systems	3
Fluid Temperature Sensors (ST760/1/2/4)	18	Dash-Logger Systems	4
Fuel Pressure Sensors (ST741/2/4/5/6/7)	17	Engineering Systems	5
General installation Guidelines	8	Stand Alone Systems	6
Harnesses		Temperature Sensors	
Extenders	10	Air (ST765/ST990)	29
Fitting into the vehicle	9	Air/ Gas (ST66x)	28
Mini sure-seal connectors	9	Thermocouple (ST66x)	28
Modifying/ Repairing	10	Oil (ST760/1/2/4)	18
Infrared Lap Timing System	19	Water (ST760/1/2/4)	18
Interference - Clearance from sources of	8	Thermocouple Interfaces (ST464/66x)	28
Lambda sensor (ST993)	29	Troubleshooting	36
Lap Timing System		Sensors	38
Lap Time Receiver	19	System and Data Download	36
Lap Time Beacon	20	Throttle/ Brake Sensor (ST779/ST979)	24
Lateral G Sensor	21	Throttle Position Sensor (ST770/ST970)	23
Linear Displacement Sensors (ST97x)	26	Water Temperature Sensors (ST760/1/2/4)	18
Mini sure seal connectors	8	Warning light - External	12
Network harness		Wiring harness installation	9
Fitting into the vehicle	12	Wiring Schematic Diagrams	32
Modifying/ Repairing	10	Configurable Dash harness (ST872-905)	32
Oil Pressure Sensors (ST744/5/6/7)	17	Data logging expansion harness (ST873)	33
Oil Temperature Sensors (ST760/1/2/4)	18	Stand Alone sensor harness (ST875)	34
		Engineering system harness (ST883)	35

